

REVISIONS				
REV.	ZONE	DESCRIPTION	DATE	BY

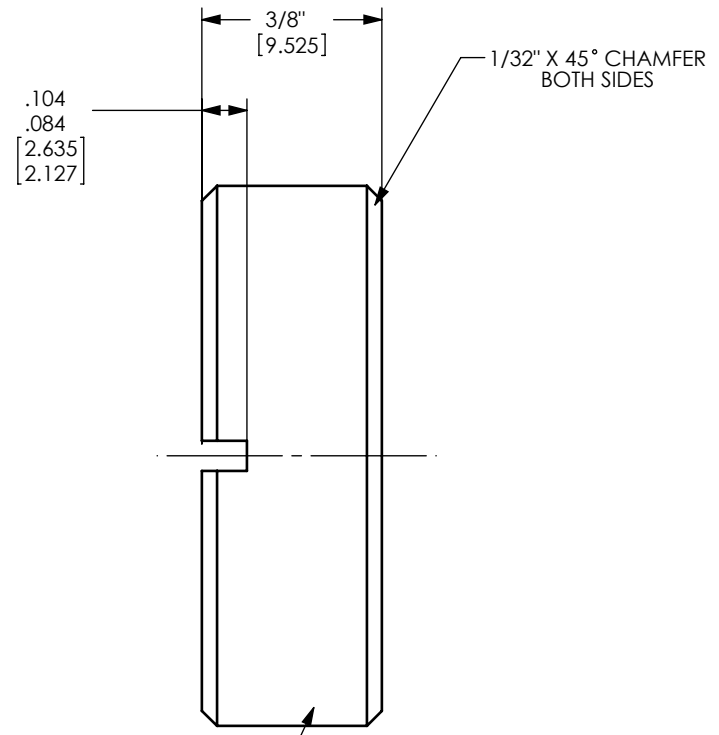
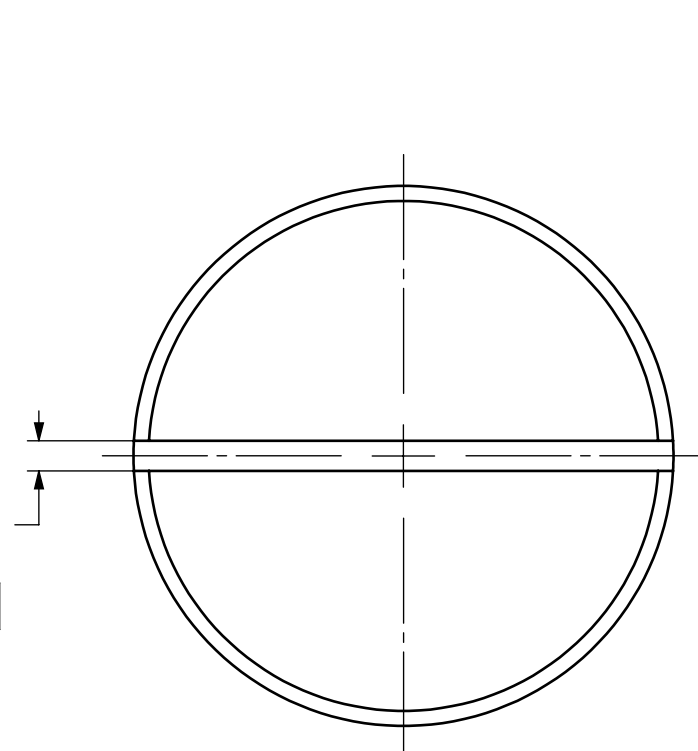

1 1/8" - 12 UNF THREAD - CLASS 2A

<b>PROPRIETARY AND CONFIDENTIAL</b>						
This drawing is owned by Dixon Valve & Coupling Co. and shall be returned upon demand. It is loaned on condition that it shall not be copied or reproduced or submitted to others without the owners consent. In accepting it subject to this condition the recipient further agrees that this drawing or any design detail or concept disclosed herein shall not be used in any way detrimental to or in competition with the owner. If the recipient does not agree to the terms of this agreement they shall return this drawing immediately. The information contained in this drawing is subject to change without notice.						
WEIGHT lbs: (kg):	DIMENSIONS GIVEN ARE	INCHES [METRIC]	INITIALS	DATE	<b>DIXON U.S.A.</b> <i>THE RIGHT CONNECTION™</i>	
PROCESS MACHINING	TOLERANCES <i>UNLESS NOTED</i> .XX ± .015 [.38]		DRFT CHK	KC	08/05/14	TITLE 1 1/8" SET SCREW
SURFACE COATING	.XXX ± .005 [.127]		ENG CHK			MATERIAL CARBON STEEL
S.M.O.D.	FINISH $\nabla$ 125		MFG CHK			
E.R.#	SCALE: 2.5:1		APPROVAL			
			SHEET	1 of 1	3RD ANGLE	SIZE <b>A</b>
			DRAWING #	1		<b>98SET</b>
						REV

5 4 3 2 1

C  
B  
A