

ITEM NO.	PART NUMBER	DESCRIPTION	MATERIAL	QTY.
1	SPORTM-6T	5-PORT ZOOMIE MANIFOLD WITH 6" MALE NPT INLET	SEE BOM	1
	<i>5PORTM-6T</i>	5-PORT ZOOMIE MANIFOLD BODY	IRON	1
	<i>O439BU</i>	O-RING	BUNA-N	5
	<i>HHBT875X175</i>	7/8" HEX HEAD BOLT x 1 3/4" LONG	CARBON STEEL	20
	<i>HUWAS225OD</i>	2 1/4" OD FLAT WASHER	CARBON STEEL	20
2	HU206600	6" FIG. 206 THREADED HAMMER UNION	CARBON STEEL / STEEL	1
3	HUF206200MT	2" FIG. 206 SERIES FEMALE HAMMER UNION x 2" MALE NPT ADAPTER	IRON	5
4	SHP100FS	1" SQUARE HEAD PLUG	STEEL	1
5	SHP200FS	2" SQUARE HEAD PLUG	STEEL	1
6	HUC206200	2" FIG.206 "BULL PLUG" STYLE CAP WITH STANDARD NUT	SEE BOM	5
	<i>HUC206200-1</i>	2" 206 SERIES BULL PLUG BODY	CARBON STEEL	1
	<i>HU206200N</i>	2" FIG.206 FRAC NUT	CARBON STEEL	1
	<i>WS-287</i>	RETAINING RING	CARBON STEEL	1
	<i>O228BU</i>	O-RING	BUNA-N	1
7	HUWAS125OD	FLAT WASHER 7/16" NOMINAL	CARBON STEEL	5
8	HUBT716X050	7/16" HEX HEAD BOLT x 1/2" LONG	CARBON STEEL	5
* 9	WSR1	KING SAFETY CABLE	STEEL	5

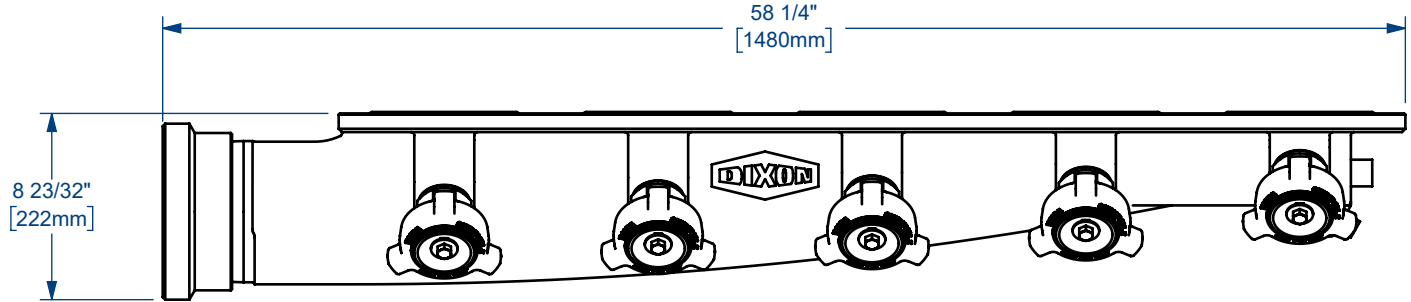

NOTE(S)
 1) ITEMS 4 AND 5 ASSEMBLED HAND TIGHT OR SEALED WITH PTFE TAPE.
 2) BOLT (HHBT875X175) AND WASHER (HUWAS225OD) IN ITEM 1, MALE END OF SUB IN ITEM 2, AND SAFETY CABLE (WSR1) ITEM 9 NOT SHOWN.

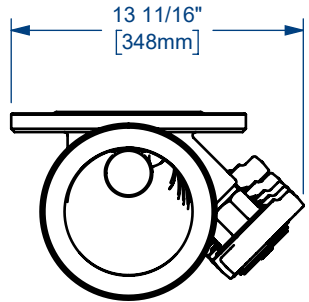

PROPRIETARY AND CONFIDENTIAL
 This drawing is owned by Dixon Valve & Coupling Co. and shall be returned upon demand. It is loaned on condition that it shall not be copied or reproduced or submitted to others without the owners consent. In accepting it subject to this condition the recipient further agrees that this drawing or any design detail or concept disclosed herein shall not be used in any way detrimental to or in competition with the owner. If the recipient does not agree to the terms of this agreement they shall return this drawing immediately. The information contained in this drawing is subject to change without notice.

DO NOT SCALE THIS DRAWING

DIXON U.S.A. <i>THE RIGHT CONNECTION™</i>	
TITLE:	5-PORT ZOOMIE MANIFOLD ASSEMBLY CUSTOMER SPECIAL
MATERIAL:	SEE BOM
PART NUMBER:	5PM-D1