

Operating & Maintenance Manual for RZL-100 Series Rotary Lobe Pumps

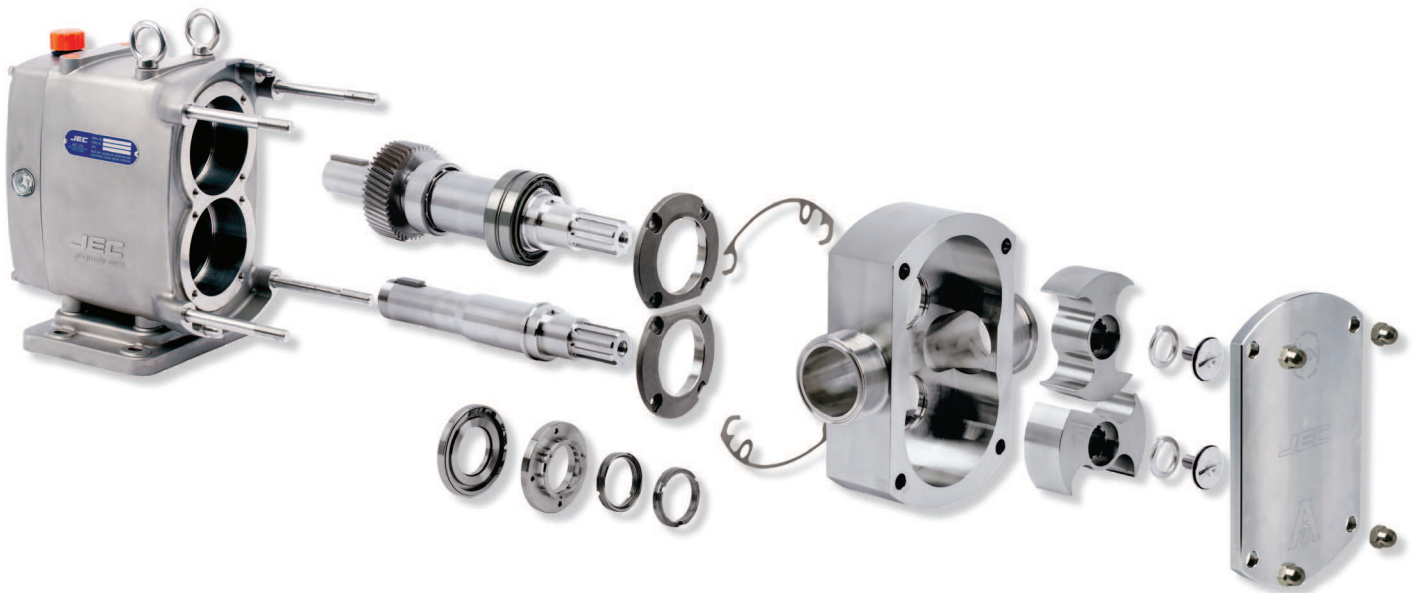

The Right Connection®

Dixon Sanitary

N25 W23040 Paul Road • Pewaukee, WI 53072

ph: 800.789.1718 • fx: 800.789.4046

dixonvalve.com

Thank you for purchasing a Dixon Sanitary Product!

This manual contains installation, operation, disassembly and assembly instructions, maintenance procedures, troubleshooting and a complete parts list for all RZL-Series positive displacement pumps.

READ THIS MANUAL carefully to learn how to service these pumps. Failure to do so could result in person injury or equipment damage. 

Table of Contents

Safety	3
Care of Stainless Steel	4
Technical Specifications	5
Family of curves	6
Unpacking Installation & Start Up.....	7-16
Tools needed.....	17
Maintenance.....	17-55
Pump Housing Disassembly	17-48
Single Mechanical Seal.....	17-25
Double Mechanical Seal.....	26-35
Single O-ring Seal	36-41
Triple Lip Seal	42-48
Inspection.....	49
Pump Housing Assembly.....	49
Rotor Clearance.....	50-52
Shimming	52
Rotor Timing	53
Gear Box Disassembly	54
Gear Box Assembly	55
Scheduled Maintenance	55
Maximum RPM	56
Maximum Solids	56
Dimensions.....	57
Troubleshooting.....	58-60
BOM	61-73
Certificates.....	74-75
Warranty.....	76

Safety Information

DO'S & DON'TS

- DO** read and understand these instructions before installing or using the pump.
- DO** use Dixon spare parts when replacing a component of the pump.
- DO NOT** service the pump while it is running.
- DO NOT** place the pump in an application where the service ratings are exceeded.
- DO NOT** modify the pump. Modifying the pump creates unsafe conditions and voids all warranties.

SAFETY PRECAUTIONS WHEN INSTALLING PUMP

- DO** use an authorized electrician when connecting the pump.
- DO** observe the mechanical limits of the pump (refer to the pump performance sheet).
- DO** install a throttling valve in the discharge line.
- DO NOT** install a throttling valve in the suction line.

SAFETY PRECAUTIONS WHEN OPERATING PUMP

- DO** allow only qualified personnel to operate this pump.
- DO NOT** start the pump until all personnel are clear.
- DO NOT** touch the pump or the lines when pumping hot fluids or when performing Clean In Place (CIP) procedures.
- DO NOT** run the pump with BOTH the suction inlet and discharge outlet blocked. Running the pump with the inlet blocked will cause serious damage to the pump.
- DO NOT** check pump rotation with liquid in the pump.
- DO NOT** run the pump with the front cover removed. The rotors and rotor case could be damaged or may cause severe injury.
- DO NOT** operate the pump with the safety guard removed.

SAFETY PRECAUTIONS WHEN SERVICING PUMP

- DO** ensure the pump is cool to touch before performing service.
- DO** relieve all pressure and drain all fluids from pump and connected piping before performing service.
- DO ENSURE POWER TO THE UNIT HAS BEEN DISCONNECTED PRIOR TO PERFORMING ANY PUMP MAINTENANCE OR CLEANING.**
- DO** exercise caution and wear protective clothing when using lye or acid for cleaning.

Care of Stainless Steel

The stainless steel components in Dixon Sanitary equipment are machined, welded and assembled by skilled craftsmen using manufacturing methods that preserve the corrosion-resistant quality of the stainless steel.

Retention of corrosion-resistant qualities under processing conditions requires regular attention to the precautions listed below.

1. Regularly check all electrical devices connected to the equipment for stray currents caused by improper grounding, damaged insulation or other defects. Corrosion: Pitting often occurs when stray currents come in contact with moist stainless steel.
2. Never leave rubber mats, fittings, wrenches, etc. in contact with stainless steel. Corrosion: Pitting or galvanic action. Objects retard complete drying, preventing air from reforming the protective oxide film. Galvanic corrosion occurs when two dissimilar metals touch when wet.
3. Immediately rinse equipment after use with warm water until the rinse water is clear. Clean the equipment (manual or CIP) as soon as possible after rinsing. Corrosion: discoloration, deposits, pitting. Product deposits often cause pitting beneath the particles.
4. Use only recommended cleaning compounds. Purchase chemicals from reputable and responsible chemical manufacturers familiar with stainless steel processing equipment, they continuously check the effects of their products on stainless steel.
5. Use cleaning chemicals exactly as specified by the manufacturer. Do not use excessive concentrations, temperatures or exposure times. Corrosion: Pitting, discoloration, stress cracks. Permanent damage often occurs from excessive chemical concentrations, temperatures or exposure times.
6. For manual cleaning, use only soft non-metallic brushes, sponges or pads. Brush with the grain on polished surfaces, avoid scratching the surface. Corrosion: Pitting, scratches. Metal brushes or sponges will scratch the surface and promote corrosion over a period of time. Metal particles allowed to remain on a stainless steel surface will cause pitting.
7. Use chemical bactericides exactly as prescribed by the chemical manufacturer in concurrence with local health authority. Use the lowest permissible concentration, temperature and exposure time possible. Flush immediately after bacterial treatment. In no case should the solution be in contact with stainless steel more than 20 minutes. Corrosion: Protective film destroyed. Chlorine and other halogen bactericides can destroy the protective film. A few degrees increase in temperature greatly increases chemical activity and accelerates corrosion.
8. Regularly inspect the joints in pipelines. Be sure all connections are tight fitting without binding. Corrosion: Crevice corrosion. Small crevices caused by improperly seated gaskets will promote crevice corrosion. Stainless steel under stress will develop stress cracking especially in the presence of bactericides containing chlorine.
9. Regularly inspect equipment for surface corrosion (i.e. pitting deposits, stress cracks, etc.). If deposit or color corrosion is detected, remove it immediately using mild scouring powder and detergents. Rinse thoroughly and allow to air dry. Review production and cleaning procedures to determine the cause. Note: If corrosion is not removed, the protective film cannot be restored and corrosion will continue at an accelerated rate.

RZL 100-Series Technical Data

Specifications:

Model	Maximum Differential Pressure (PSI) ¹	Maximum Flow Rate (GPM)
105	290	10
110	290	24
115	174	48
120	116	77

¹ Up to 435 PSI (30 bar) is available with Front Bearing Cover

- Temperature range: 14°F to 356°F (-10°C to 180°C), above 248°F (120°C) may require Hot Clearance Rotors
- Viscosity range: Up to 1,000,000 cPs
- Noise level: 60 ~ 80 dB

Materials:

- Product wetted steel part: AISI 316L Stainless Steel (standard)
- Product wetted elastomers: EPDM (standard)
- Optional seals: Buna, FKM, PTFE Encapsulated and Perfluor

Shaft Seals:

- Seal options: Single and Double Mechanical, Single and Double O-Ring and Triple Lip-seal
- Maximum flushing water pressure: 7 PSI (0.5 bar)
- Flushing water consumption: 30~60 cubic inches/min (0.25~0.5 liter/min)
- Stationary seal ring material: Tungsten Carbide
- Rotating seal ring material: Tungsten Carbide (standard) or Silicon Carbide (optional)
- O-ring material: EPDM (standard)
- Optional O-ring material: Buna, FKM & Perfluor
- Triple lip seal material: PTFE(Polytetrafluoroethylene)+Glass (standard) or PTFE+Copper (optional)

Rotor Information: Not all rotors available in all models.

- Single/bi-wing and bi-lobe/tri-lobe/heli-lobe are interchangeable
- Optional rotors: Multi-lobe, PTFE Coated, Hardened & Rubber Heli-lobe

Optional Information:

- Ultra clean version
- High pressure version up to 435 PSI (30 bar)
- Heating jacket on rotor case and front cover
- Rectangular inlet version
- Pressure relief front cover (not 3A)
- Surface hardening

Family of Curves

Rotary Lobe Pump Composite

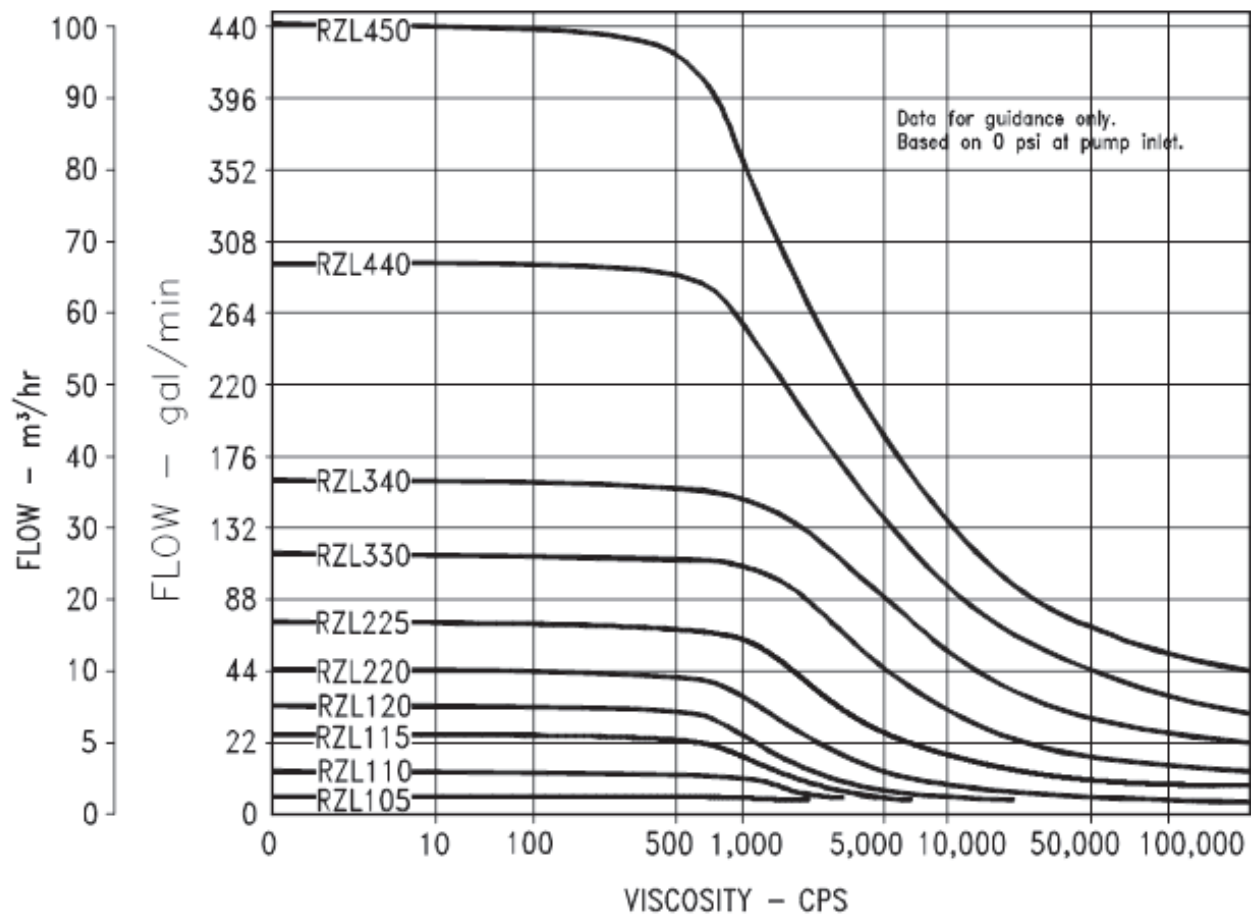

Unpacking

Carefully unpack all parts of the pump and inspect for damage that may have occurred during shipment. Report any damages to the carrier immediately.

The ports on the pump are protected with a plastic cover. If any covers are missing or damaged, inspect the ports on the pump thoroughly for any damage.

If you are receiving a complete base mounted unit, please check shaft alignment as it may have changed during shipment.

The drawing below shows how the pump should be lifted. Ensure that the lifting equipment is correctly rated.

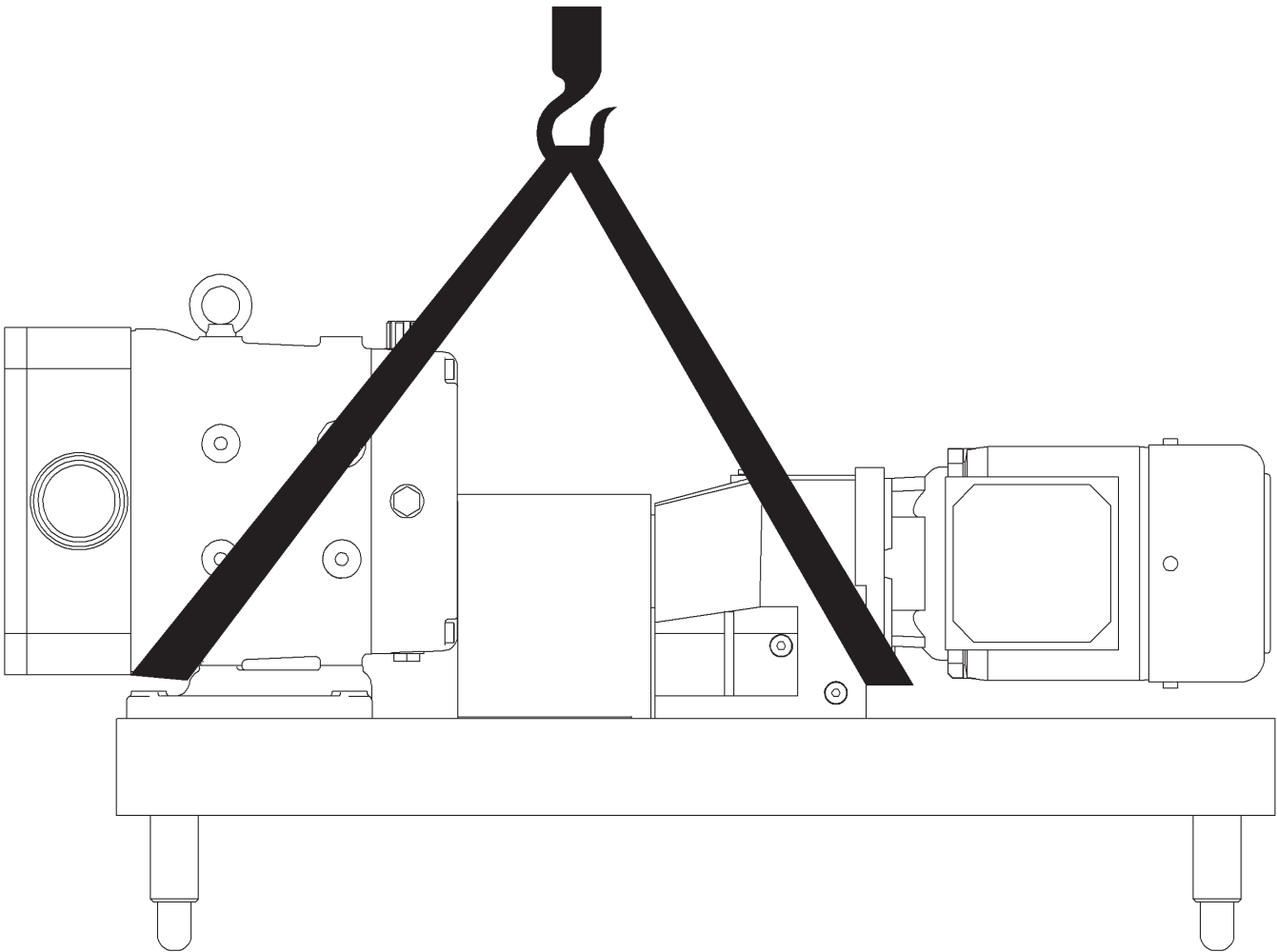

Installation & Start Up

Mounting Configurations

Pump Mounting Adjustable:

- Adjustable leg base, commonly used for sanitary pumps for wash down under base. Can be easily moved or repositioned.

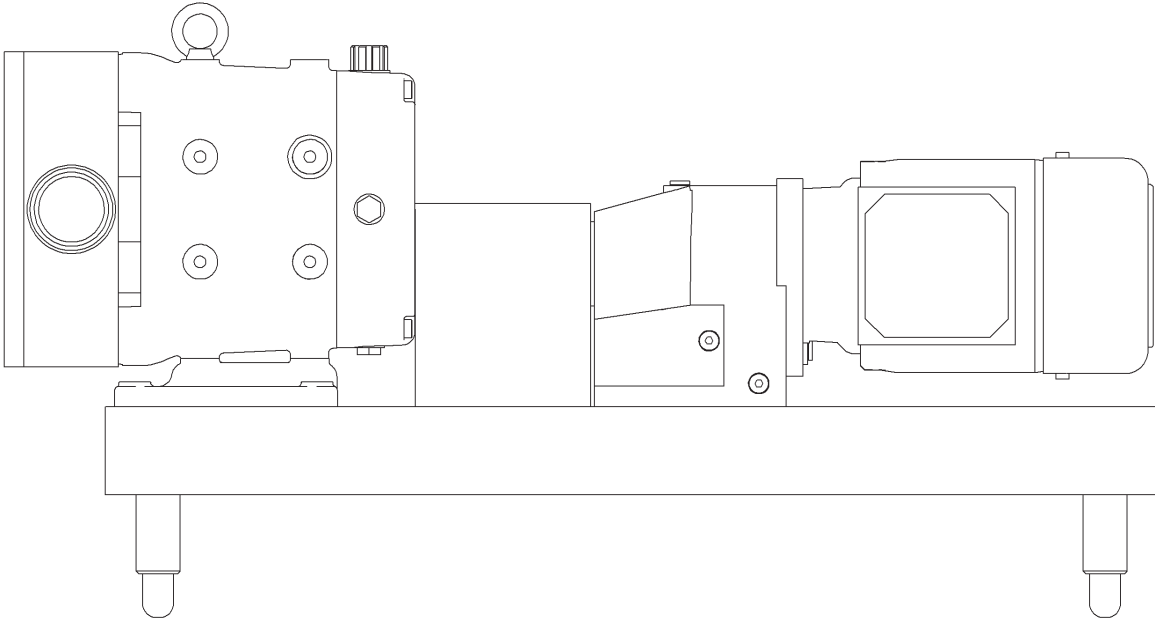

Pump Mounting Casters:

- Portable bases – for movement to different locations. Can also be mounted on a cart with handles.

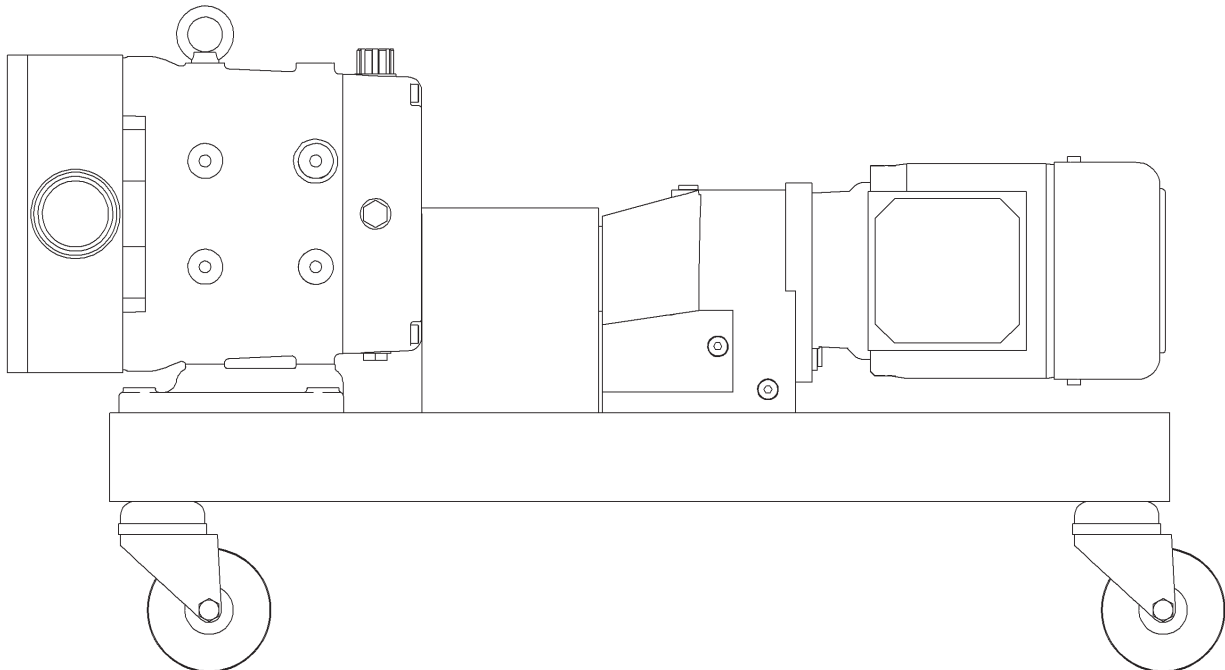

Installation & Start Up

Proper Installation

Piping Support:

- Weight of piping and fluid – support piping independently with hangers or pedestals. On rectangular inlet flange pumps, hopper should also be supported independently.

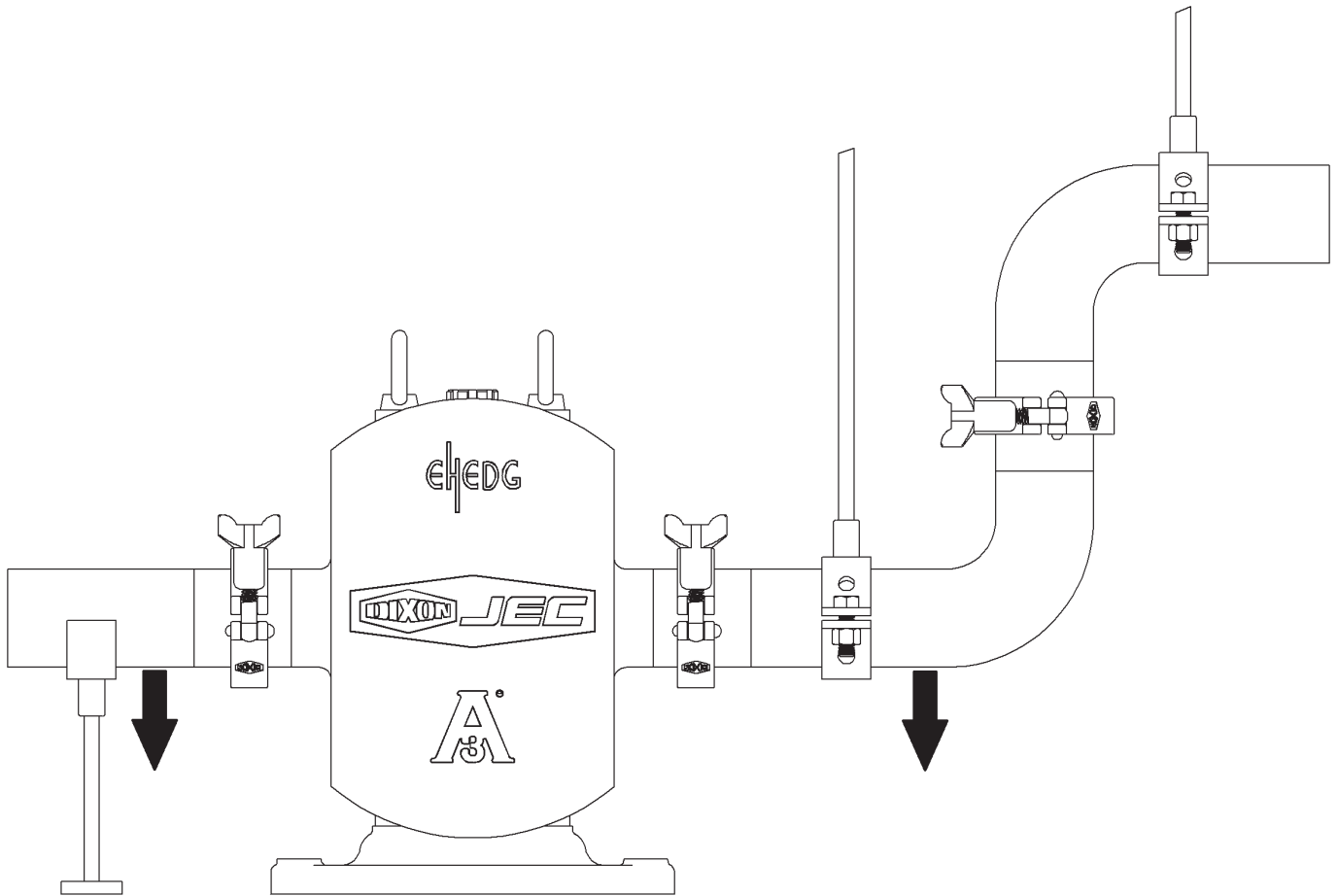

Installation & Start Up

Proper Installation (continued)

Piping Slope:

- Inlet side – slope piping up to inlet to avoid air pocket.

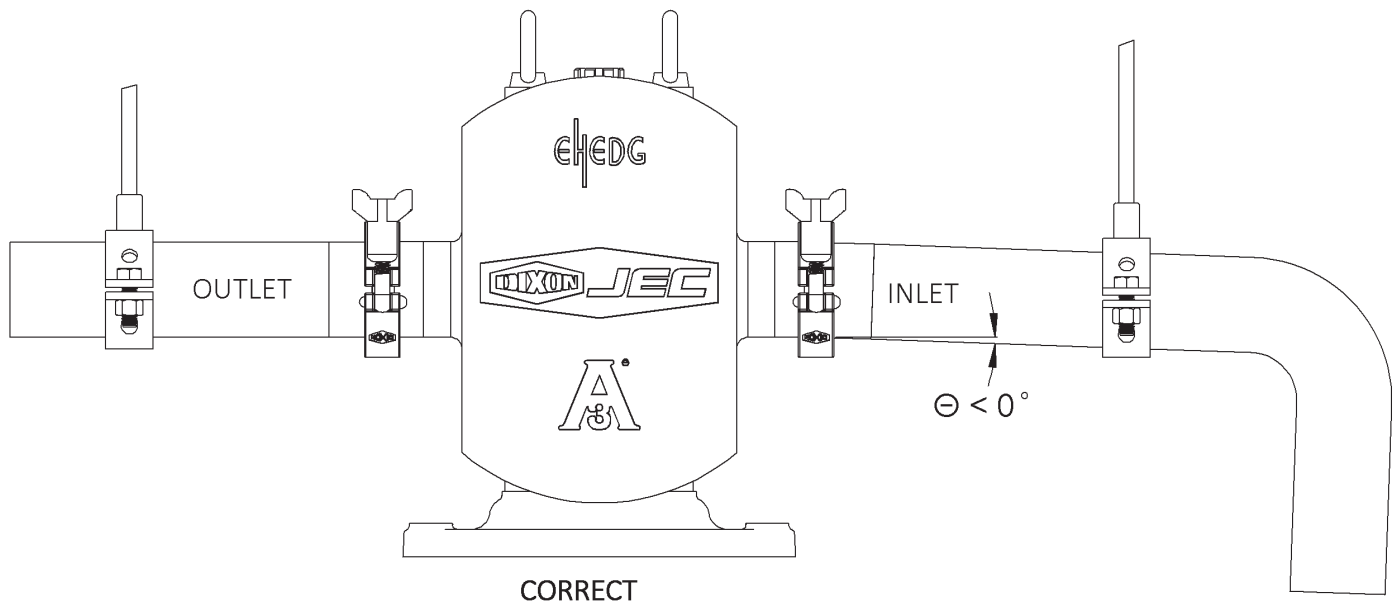
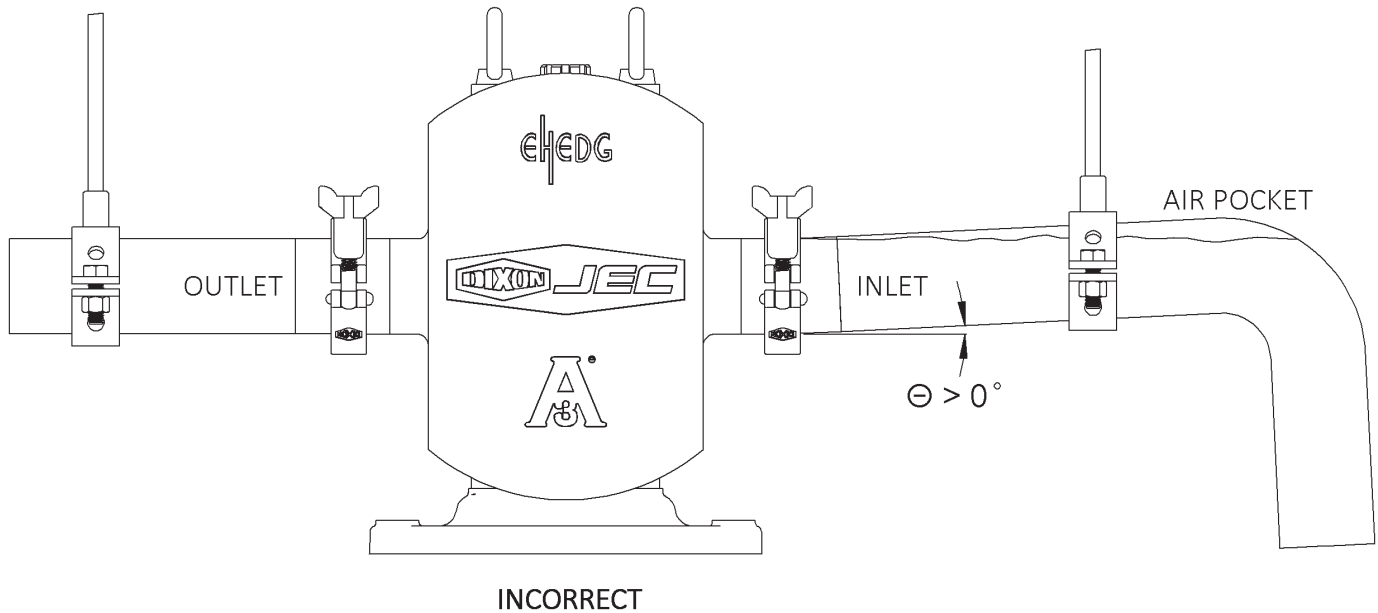

Installation & Start Up

Proper Installation (continued)

Pressure Gauges:

Pressure and vacuum gauges provide the easiest way to tell you something about the pump operation.

- Normal or abnormal pressures
- Overflow conditions
- Indication of flow
- Changes in pump condition
- Changes in system conditions
- Changes in fluid viscosity

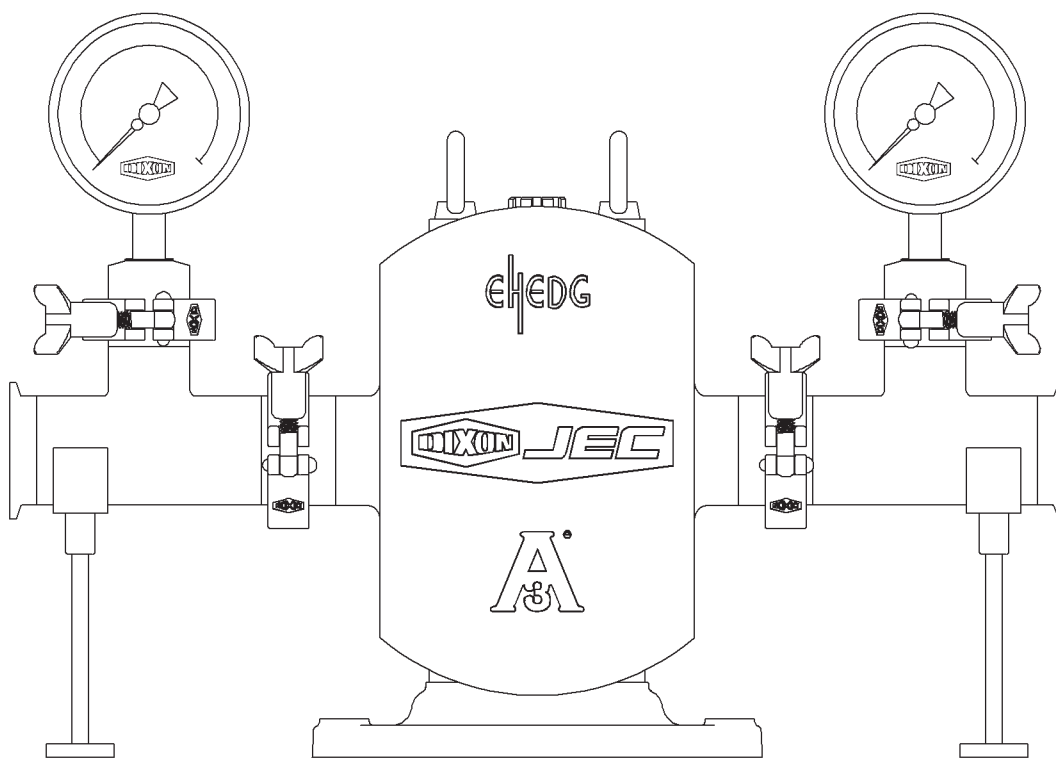

Installation & Start Up

Proper Installation (continued)

Inlet Check Valve:

- Inlet side – use check valves to keep inlet line full, particularly with low viscosity fluids, and in start-stop operation.

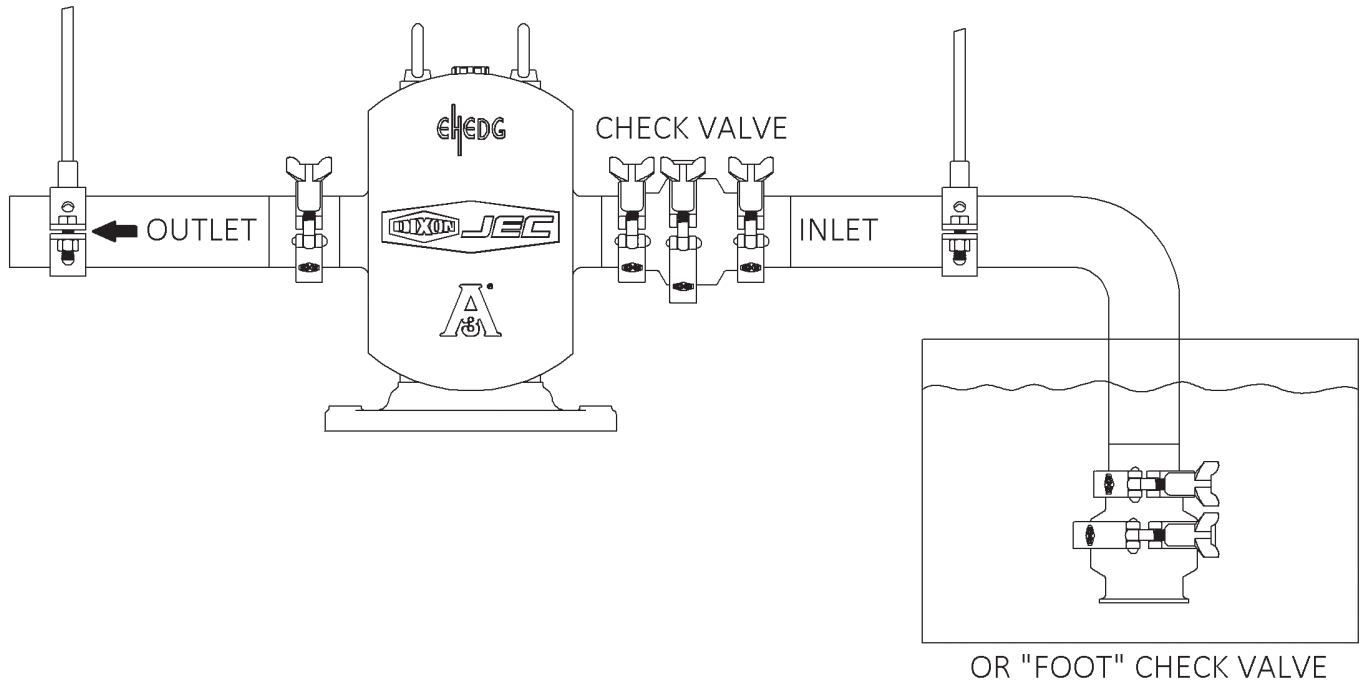

Outlet Check Valve:

- Inlet Vacuum Service – use check valve on outlet side.
- Prevents backflow (air or fluid)
- Facilitates initial start-up (minimizes differential pressure pump must supply to start flow)

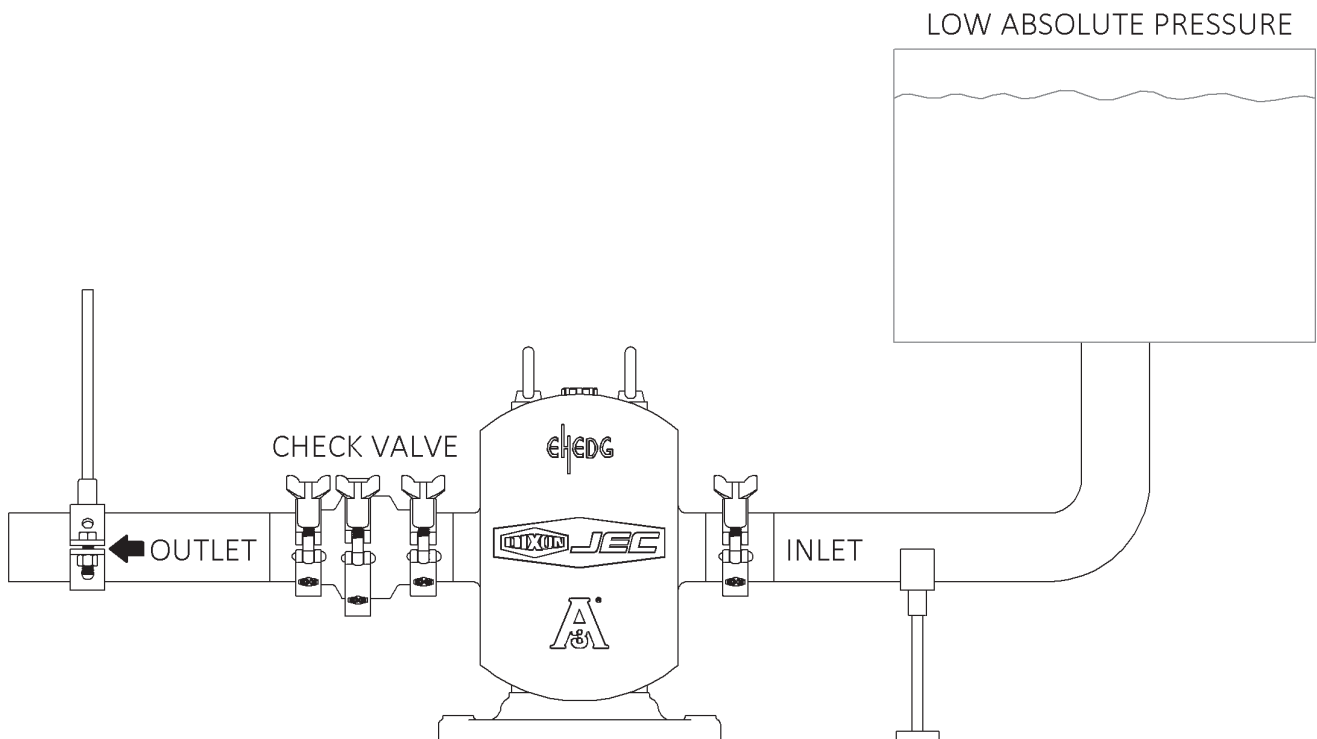

Installation & Start Up

Proper Installation (continued)

Thermal Expansion:

- Thermal expansion of piping can cause tremendous forces. Use thermal expansion joints to minimize forces on pump. Flexible joints can also be used to limit the transmission of mechanical vibration. Anchor free ends of any flexible hose in system.

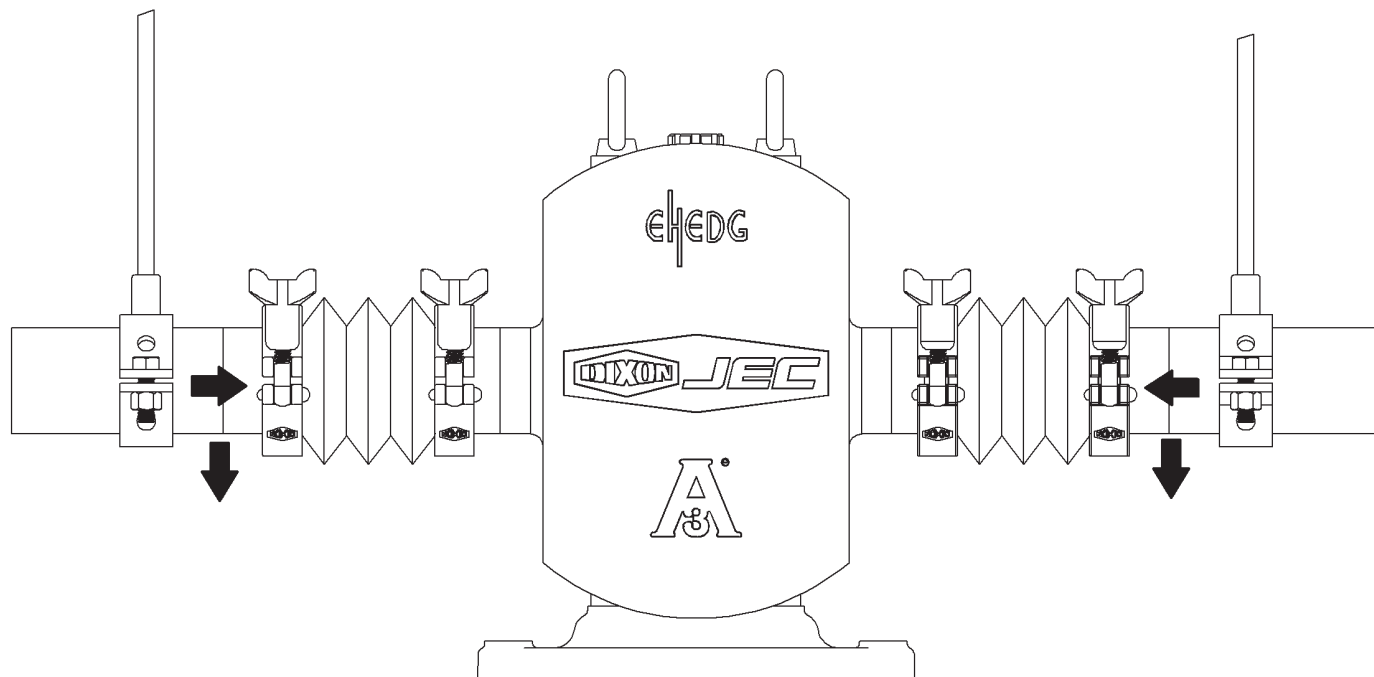

Isolation Valves:

- Isolation Valves – permit pump maintenance and removal safely without emptying entire system.

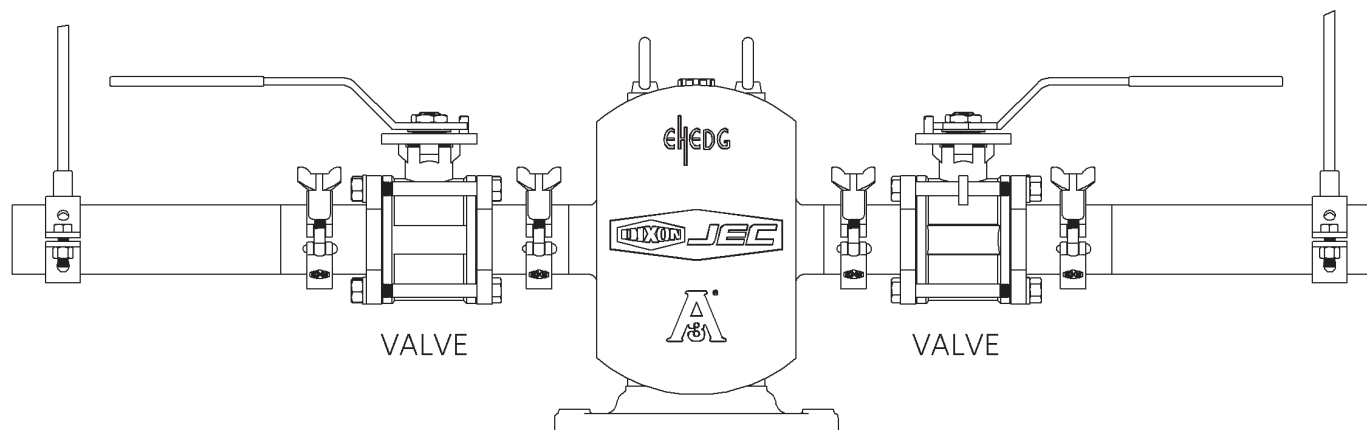

Installation & Start Up

Proper Installation (continued)

Relief Loop:

- Relief Valve – To protect the pump and piping system against excessive pressure, a relief valve should be installed. An integral relief valve, designed to bypass the fluid internally from the pump outlet to the inlet, should not be used on applications where the discharge must be closed for more than a few minutes. Prolonged operation of the pump with closed discharge will cause heating of the fluid circulating through the relief valve.

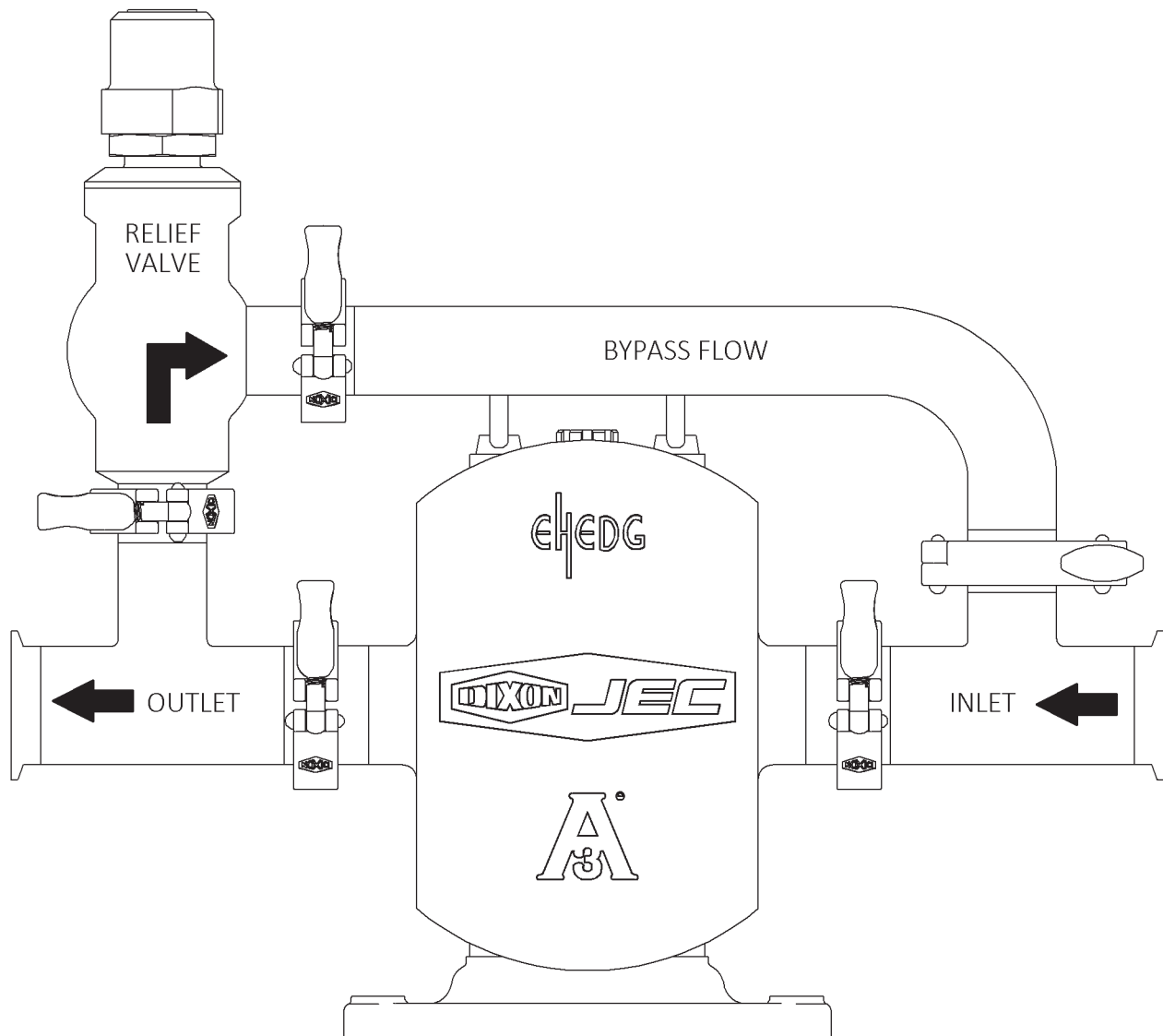

Installation & Start Up

At Start Up

Pump Flow:

- All pumps are labeled with flow direction based on motor being wired for clockwise rotation. If motor is wired for counterclockwise rotation, flow direction will be opposite of what is indicated on pump head.

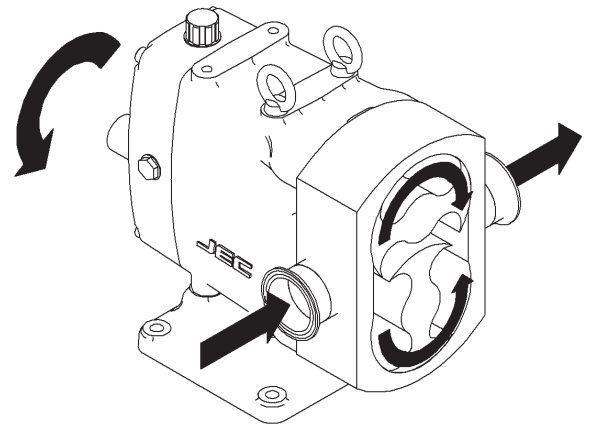
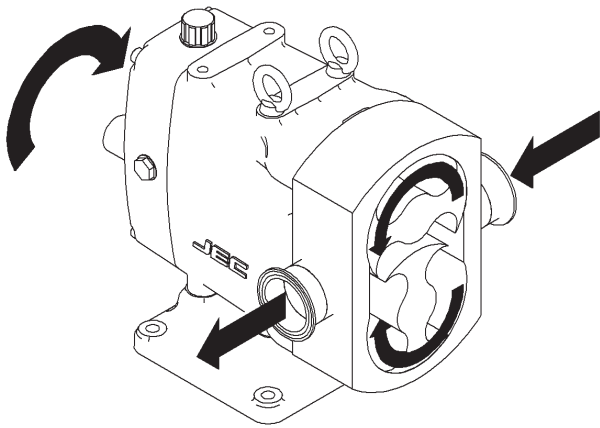
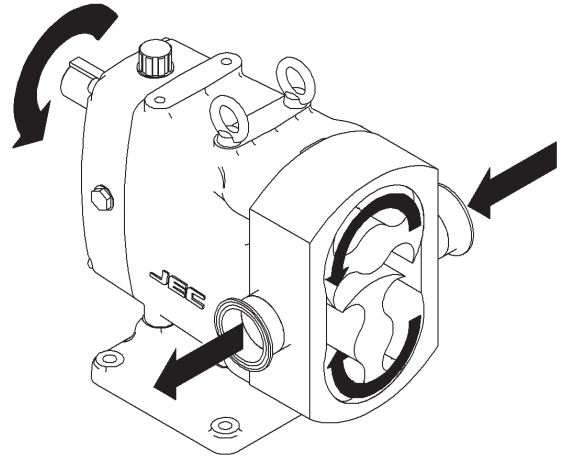
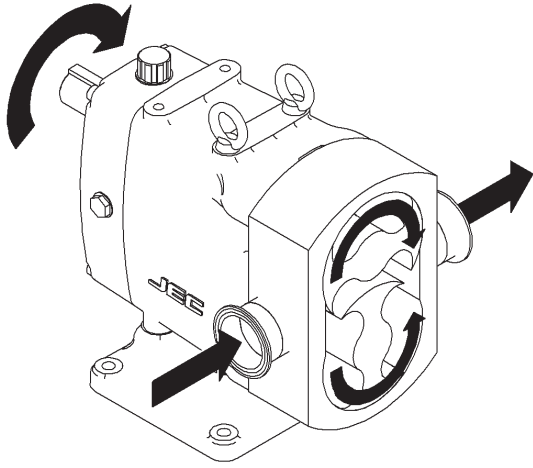

Installation & Start Up

At Start Up

Pump Alignment:

- A flexible coupling is used to compensate for end play and small differences in alignment. The pump and drive shaft should be aligned as closely as possible.
- Check angular alignment using feeler or taper gauge.
- Adjust to get equal dimension at all points – at the same time, set space between coupling halves to the coupling manufacturer's recommended distance.
- Note: Pump is aligned prior to shipping, after installation verify alignment as misalignment may have occurred during shipment.

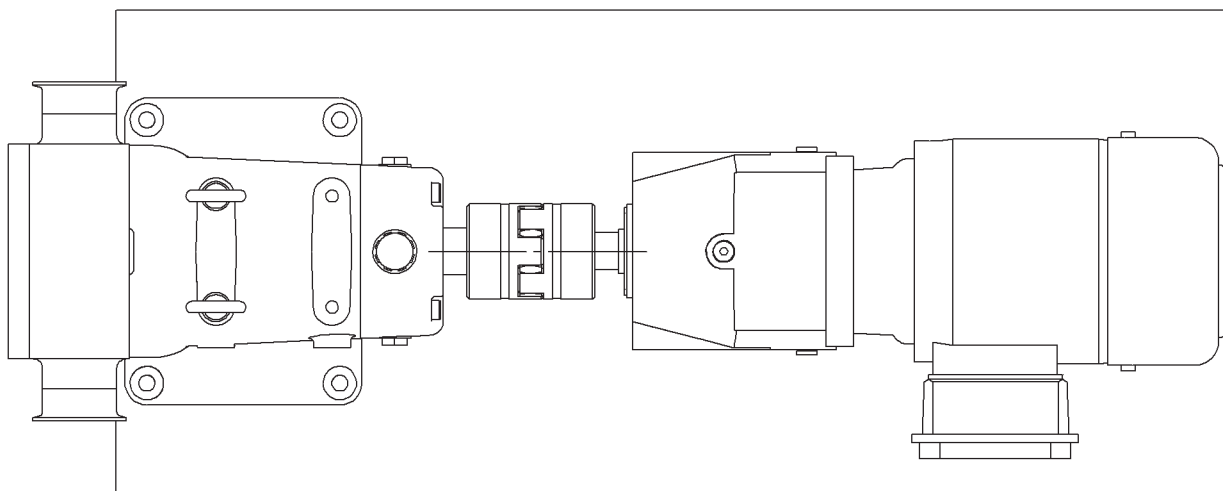
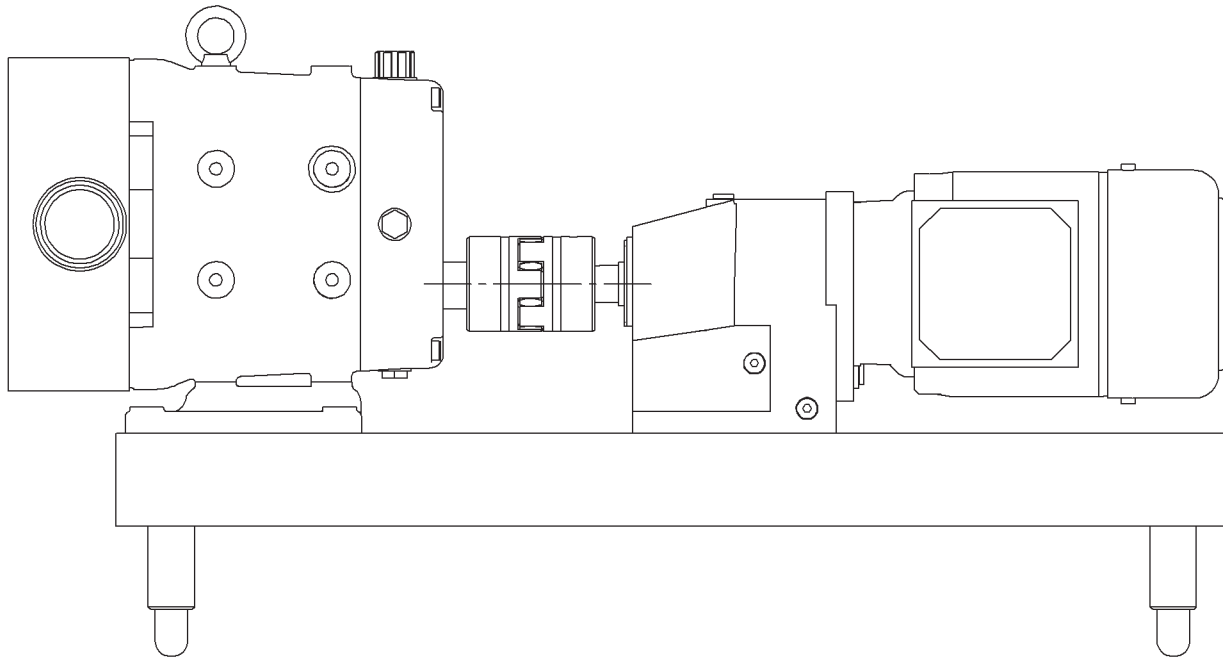

Tools Needed

- Rotor tool
- Plastic dowel
- Open ended wrench set
- Rubber mallet
- Flat head screw driver
- Feeler gauges
- Hex keys
- O-ring pick
- Spanner wrench
- Rotor extraction tool (optional)

Additional tools needed when assembling or disassembling gear box

- Spanner wrench
- Arbor press or bearing puller

Maintenance

Pump Housing Disassembly - Single Mechanical Seal

! Prior to removal of pump, the shut-off valves in the suction and discharge lines must be closed. If there is any risk that product may harden, crystallize or freeze in the pump it should be thoroughly drained and cleaned immediately after use. Same attention applies if there is a seal flush option. Power needs to be locked out to prevent unintended start of the pump.

Note: Reference numbers are listed in the sectional view located on pages 61-73.

1. Loosen and remove the four hex nuts (33) from the front cover.



Maintenance

Pump Housing Disassembly - Single Mechanical Seal (continued)

2. Remove the cover (32). If it is stuck, tap the cover with a soft hammer.

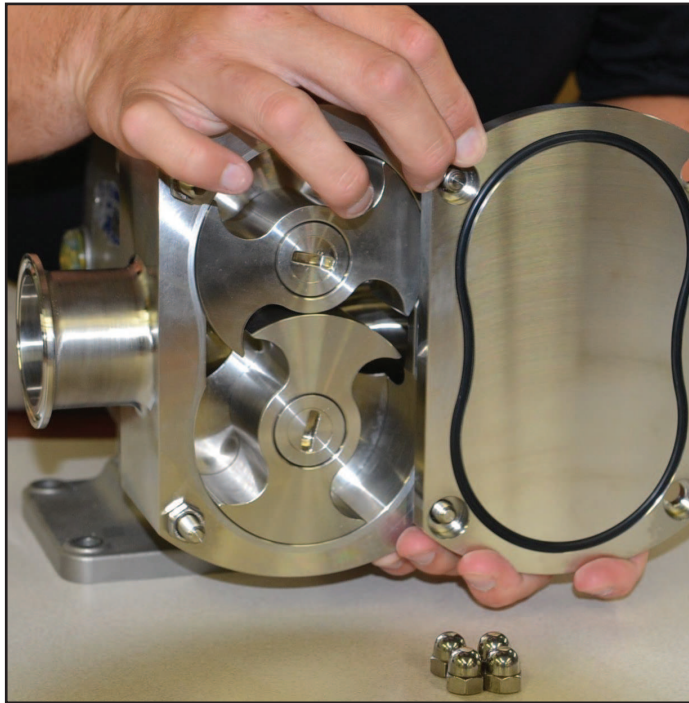

3. Remove the cover O-ring (34).

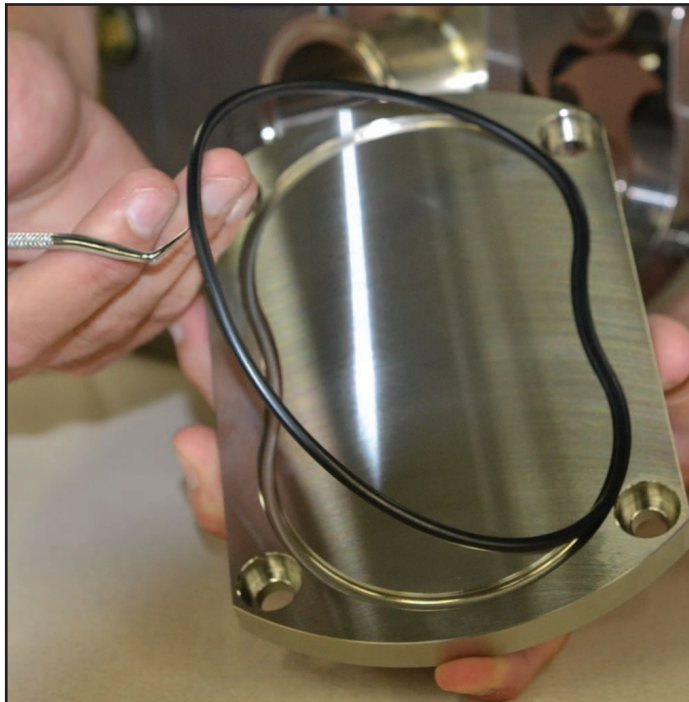

Maintenance

Pump Housing Disassembly - Single Mechanical Seal (continued)

4. Remove the rotor retaining bolts (35). To remove the rotor retaining bolts, place the dowel between the rotors. Turn the first rotor bolt counter-clockwise.

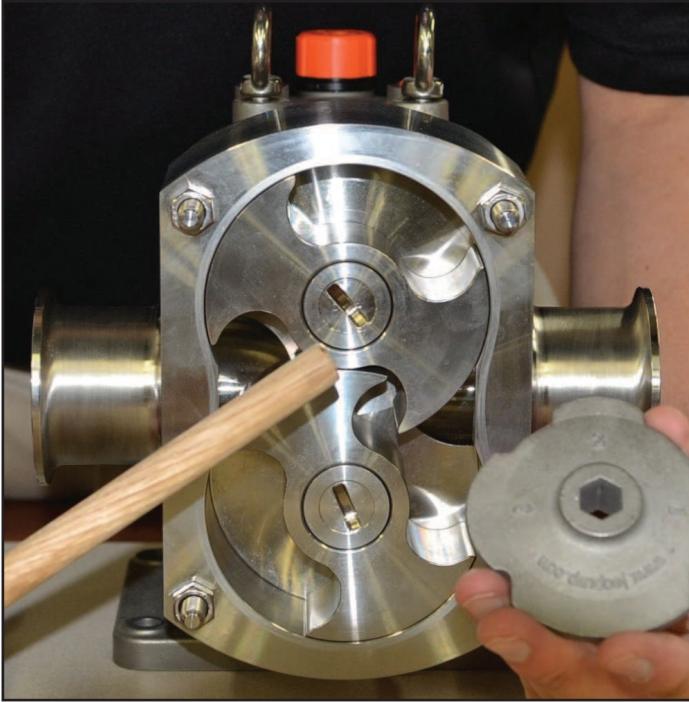

5. Remove the rotor bolts (35), spring washers (36) and O-ring (37).



Maintenance

Pump Housing Disassembly - Single Mechanical Seal (continued)

6. Remove the rotors (38) from the pump housing (31) by pulling straight.

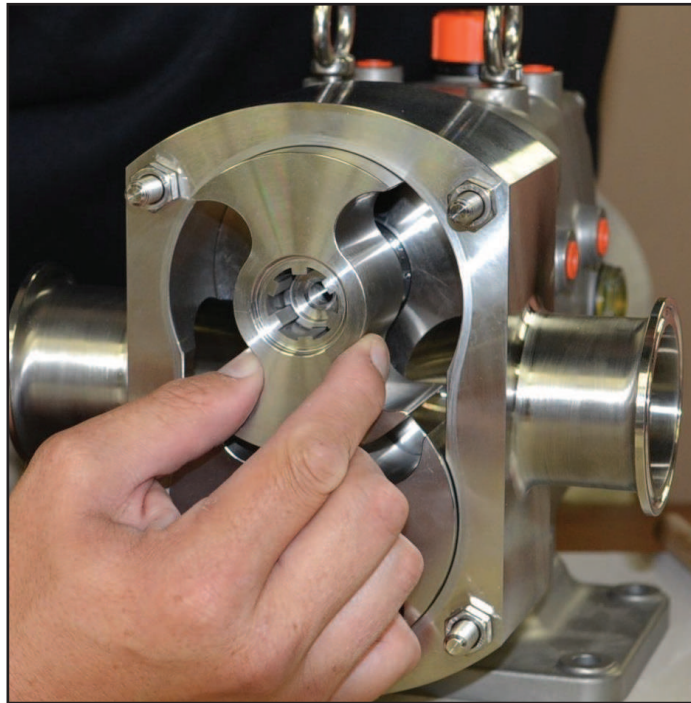

6a. If the rotors (38) will not come out freely, remove the stud bolt hex nuts (46) and then tap on the back of the inlet and outlet ports with a soft hammer. Once the rotors (38) are loose, then push the casing (31) back towards the gear box and remove the rotors.

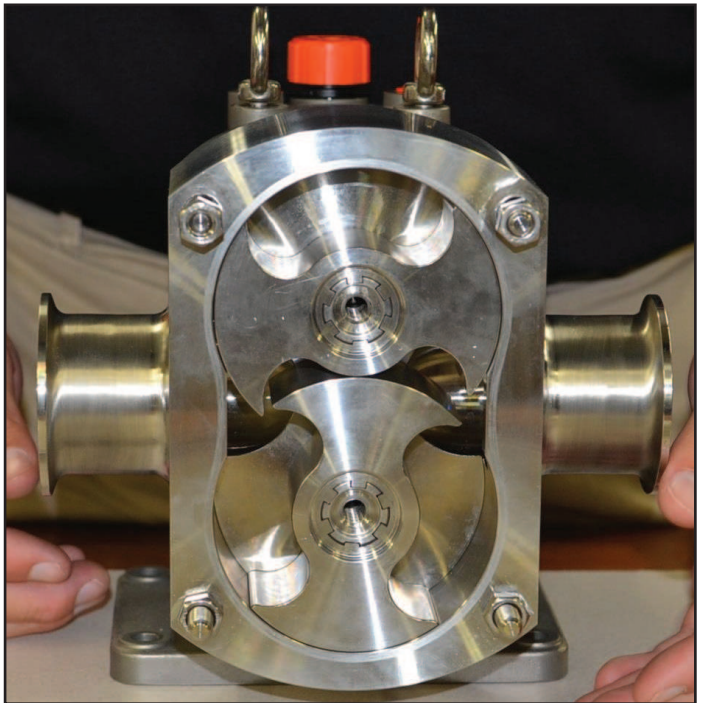
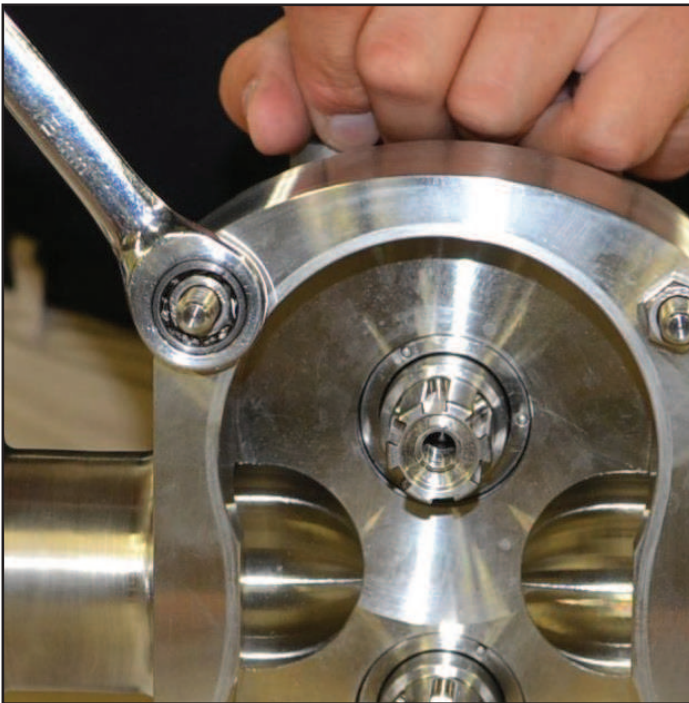

Maintenance

Pump Housing Disassembly - Single Mechanical Seal (continued)

6a, continued

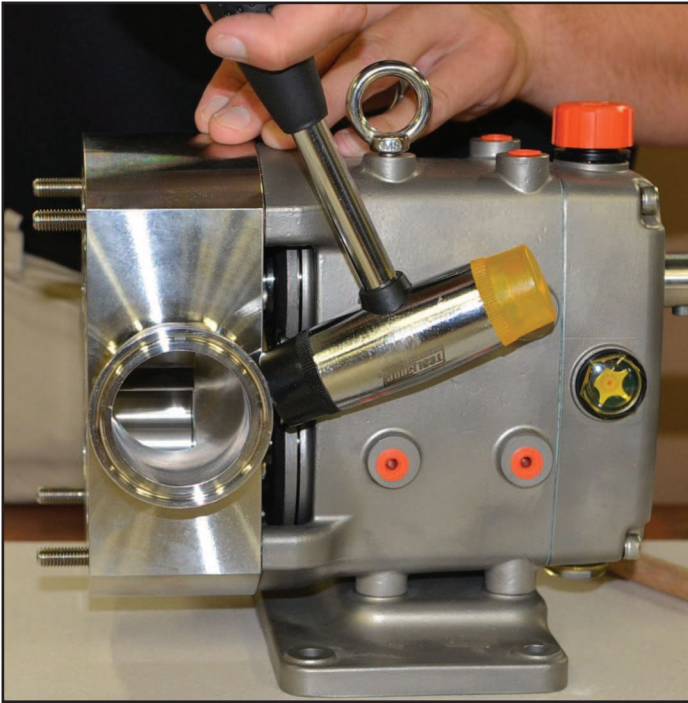

Maintenance

Pump Housing Disassembly - Single Mechanical Seal (continued)

7. Remove the seal ring (52) from the back of the rotor (38).

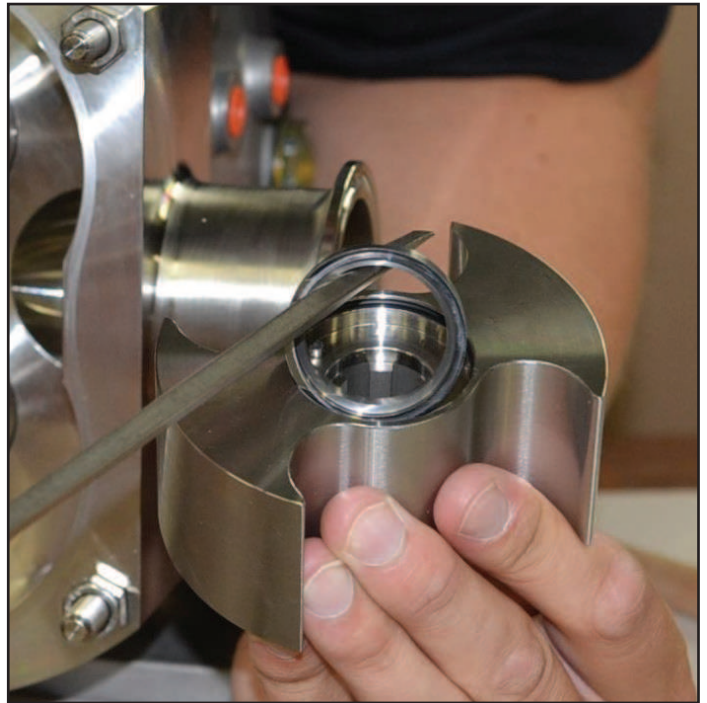

8. Remove the rotor O-rings (51).



Maintenance

Pump Housing Disassembly - Single Mechanical Seal (continued)

9. Remove the casing seal rings (52).

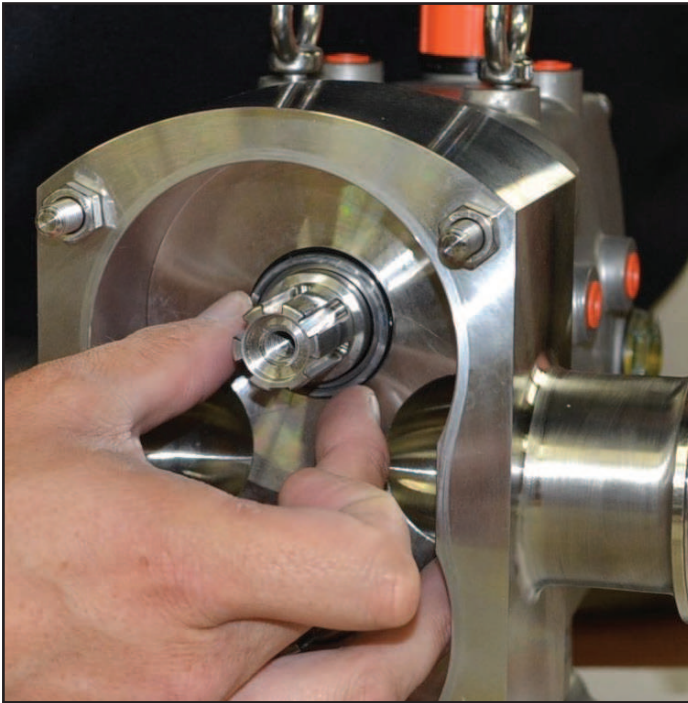

10. Remove the stud bolt hex nuts (46).

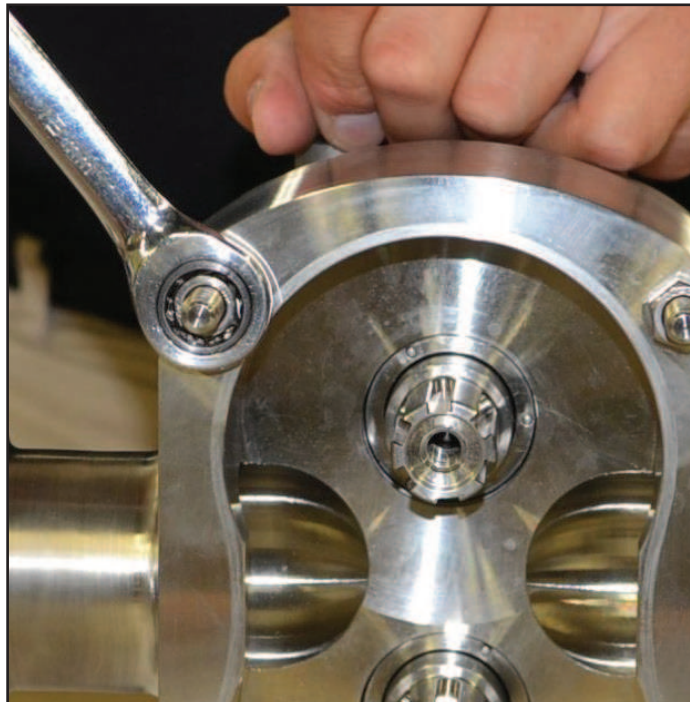

Maintenance

Pump Housing Disassembly - Single Mechanical Seal (continued)

11. Remove the rotor case (31).

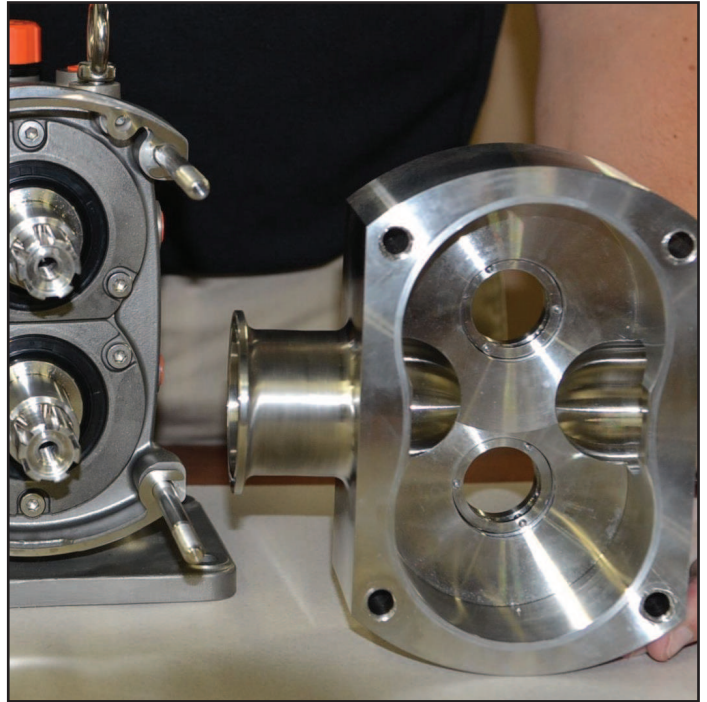
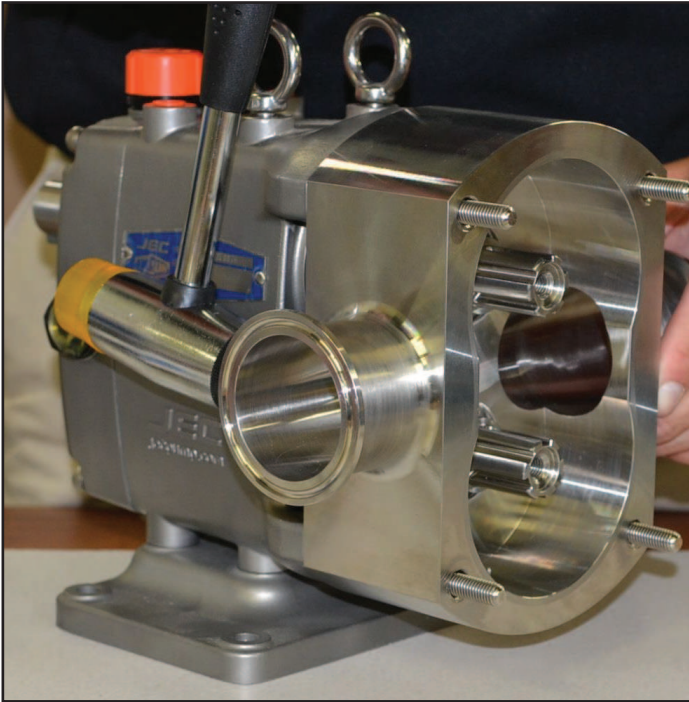

12. Remove the rotor case O-ring (53). This can be done before you remove the casing or after.

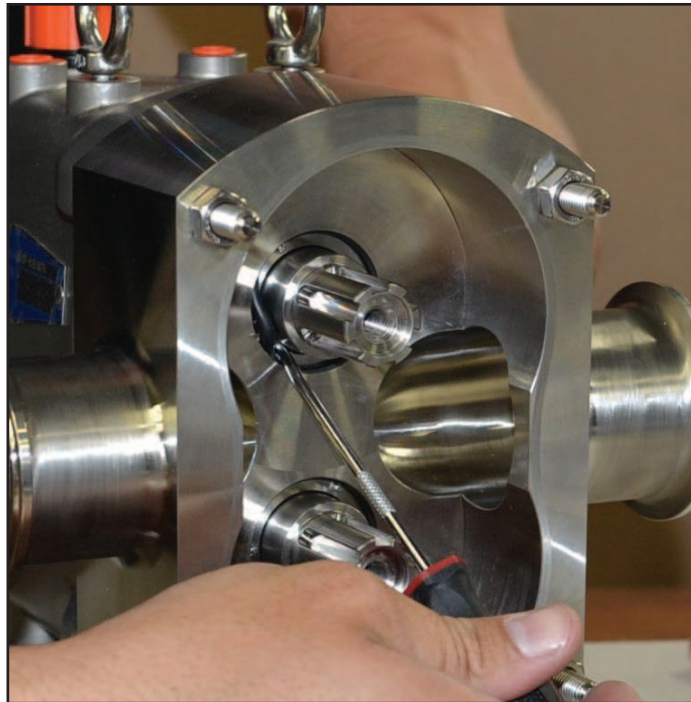

Maintenance

Pump Housing Disassembly - Single Mechanical Seal (continued)

13. On the back of the rotor case, remove the four mechanical seal gland wrench bolts (42 & 43).

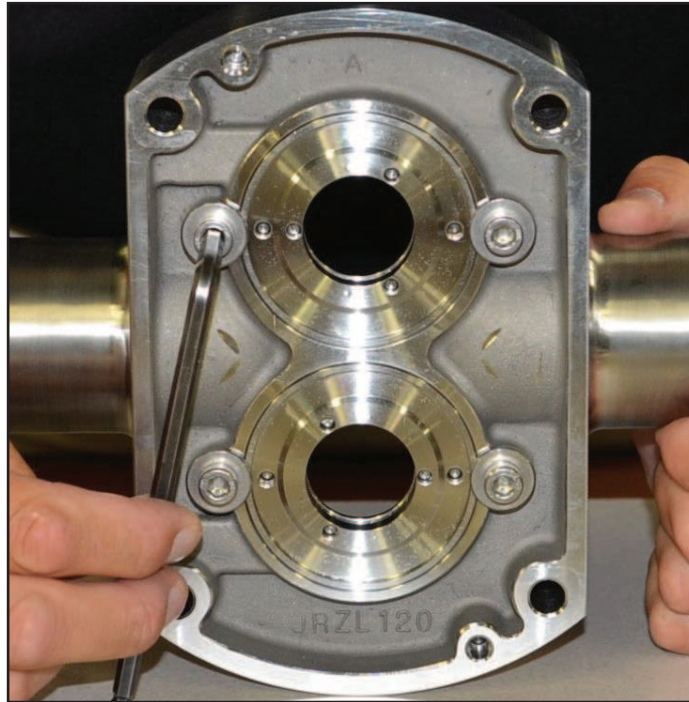

14. Remove the single seal body cases (54).

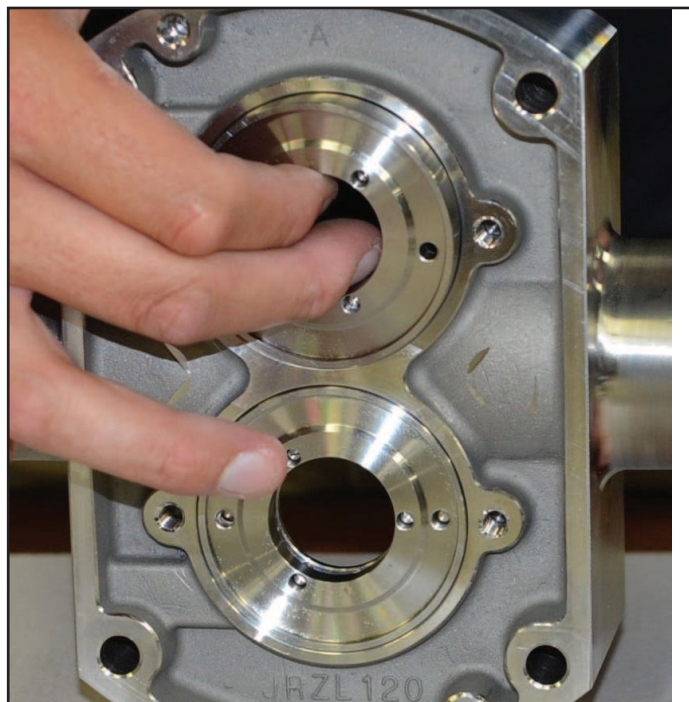

Maintenance

Pump Housing Disassembly - Double Mechanical Seal

 Prior to removal of pump, the shut-off valves in the suction and discharge lines must be closed. If there is any risk that product may harden, crystallize or freeze in the pump it should be thoroughly drained and cleaned immediately after use. Same attention applies if there is a seal flush option. Power needs to be locked out to prevent unintended start of the pump.

Note: Reference numbers are listed in the sectional view located on pages 61-73.

1. Loosen and remove the four hex nuts (33) from the front cover.



2. Remove the cover (32). If it is stuck, tap the cover with a soft hammer.

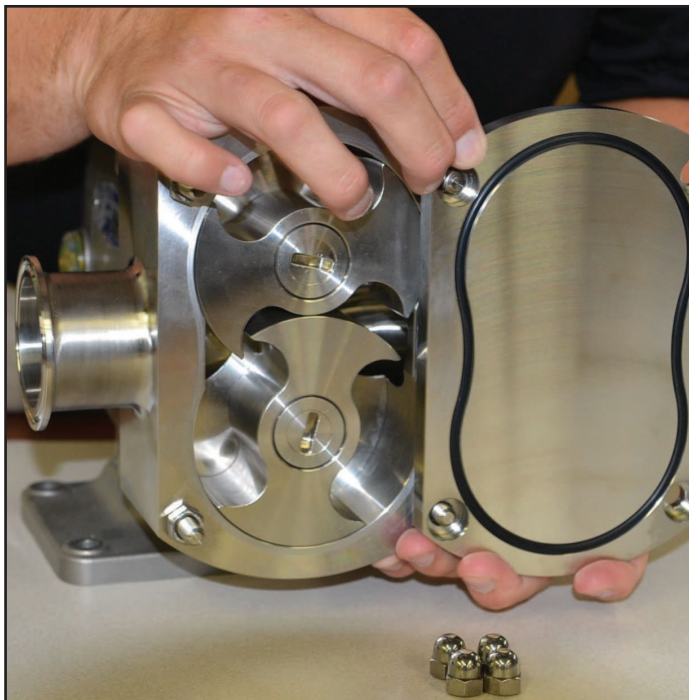

Maintenance

Pump Housing Disassembly - Double Mechanical Seal (continued)

3. Remove the cover O-ring (34).

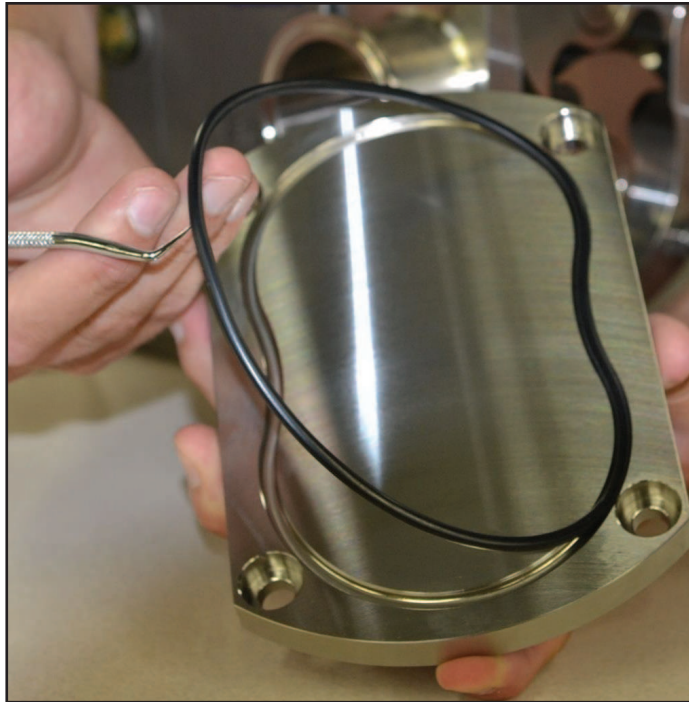

4. Remove the rotor retaining bolts (35). To remove the rotor retaining bolts, place the dowel between the rotors. Turn the first rotor bolt counter-clockwise.

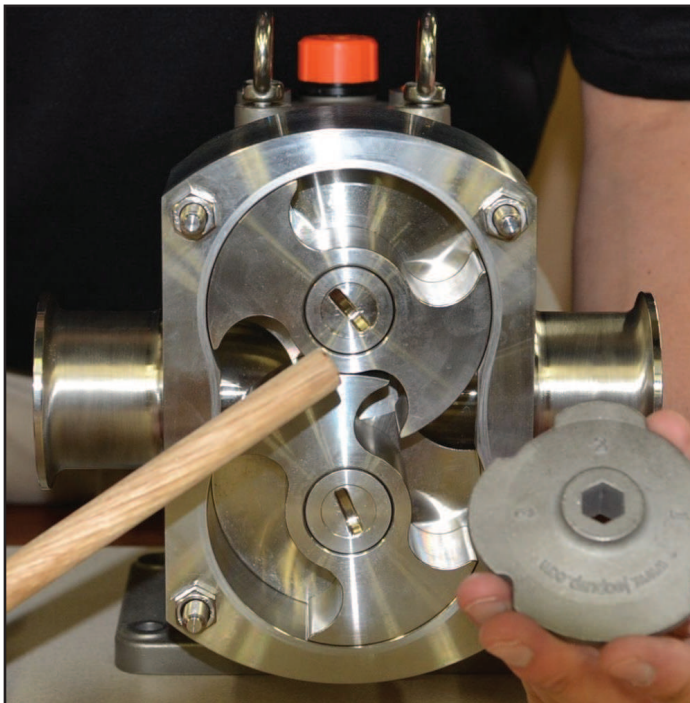

Maintenance

Pump Housing Disassembly - Double Mechanical Seal (continued)

5. Remove the rotor bolts (35), spring washers (36) and O-ring (37).



6. Remove the rotors (38) from the pump housing (31) by pulling straight.

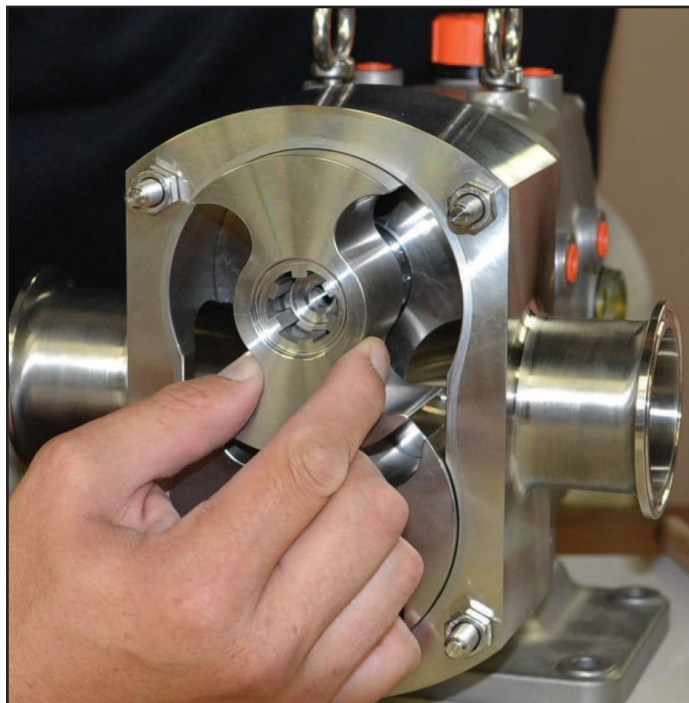

Maintenance

Pump Housing Disassembly - Double Mechanical Seal (continued)

6a. If the rotors (38) will not come out freely, remove the stud bolt hex nuts (46) and then tap on the back of the inlet and outlet ports with a soft hammer. Once the rotors (38) are loose, then push the casing (31) back towards the gear box and remove the rotors.

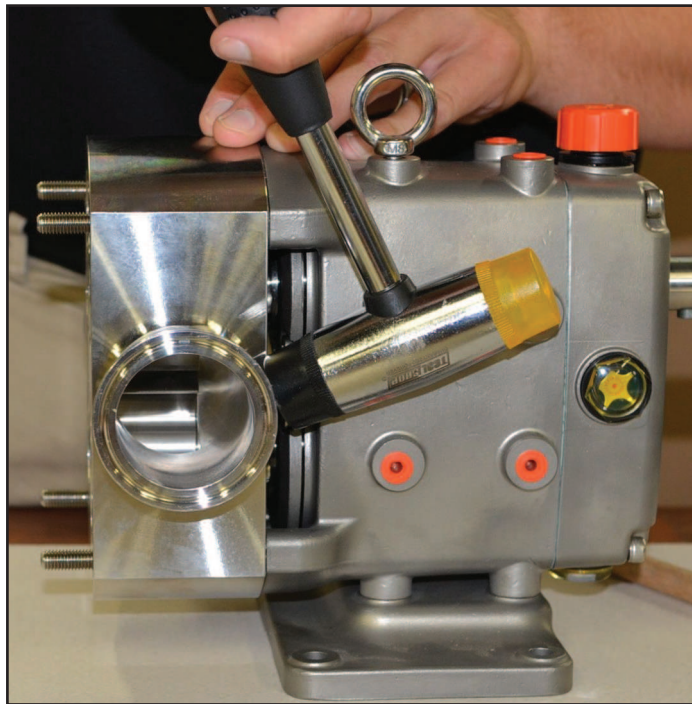
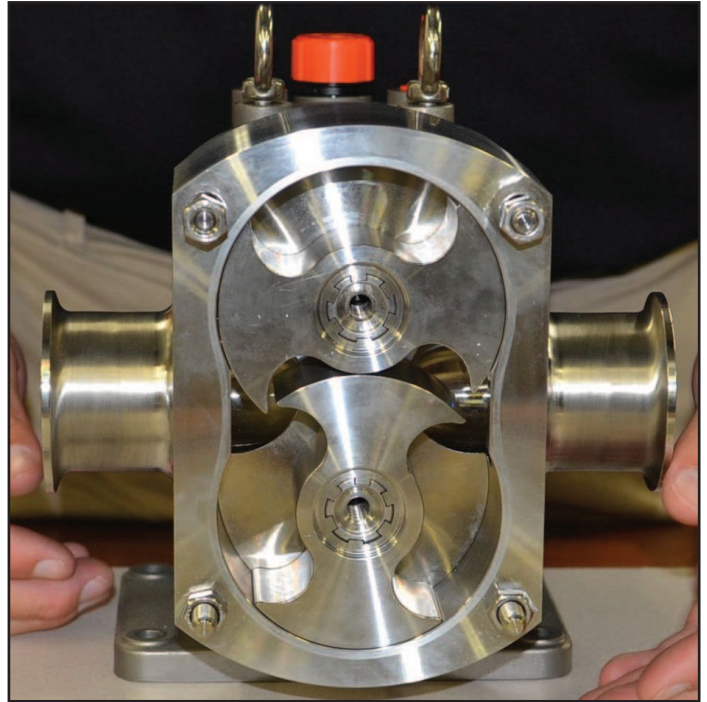

Maintenance

Pump Housing Disassembly - Double Mechanical Seal (continued)

6a, continued



7. Remove the seal ring (52) from the back of the rotor (38).



Maintenance

Pump Housing Disassembly - Double Mechanical Seal (continued)

8. Remove the rotor O-rings (51).



9. Remove the casing seal rings (52).

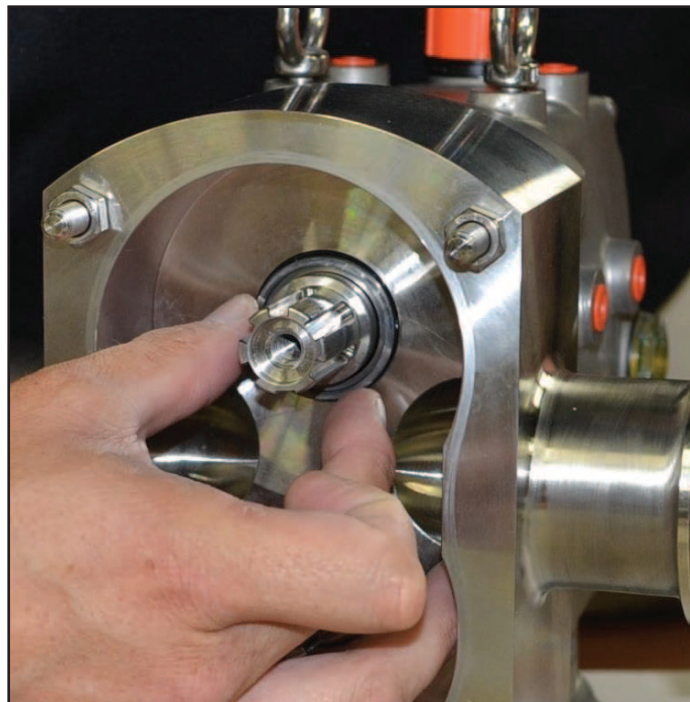

Maintenance

Pump Housing Disassembly - Double Mechanical Seal (continued)

10. Remove the stud bolt hex nuts (46).

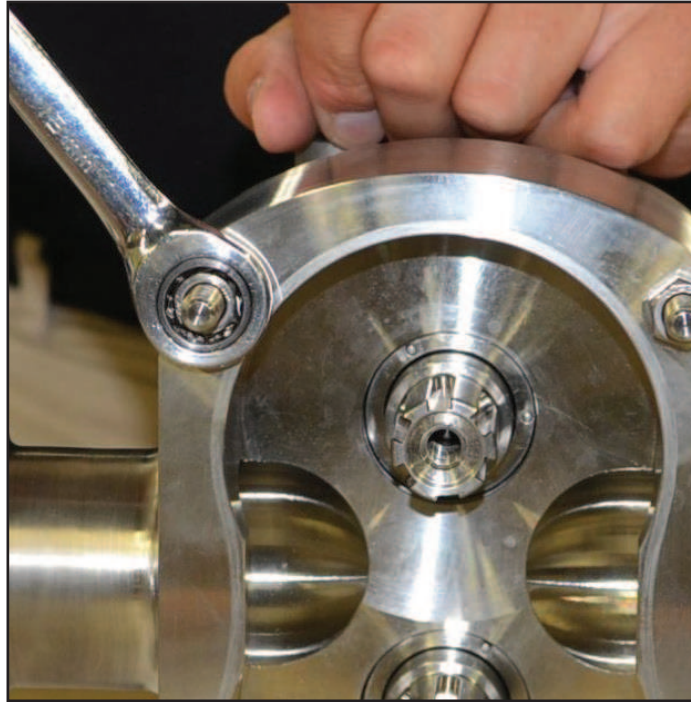

11. Remove the rotor case (31).

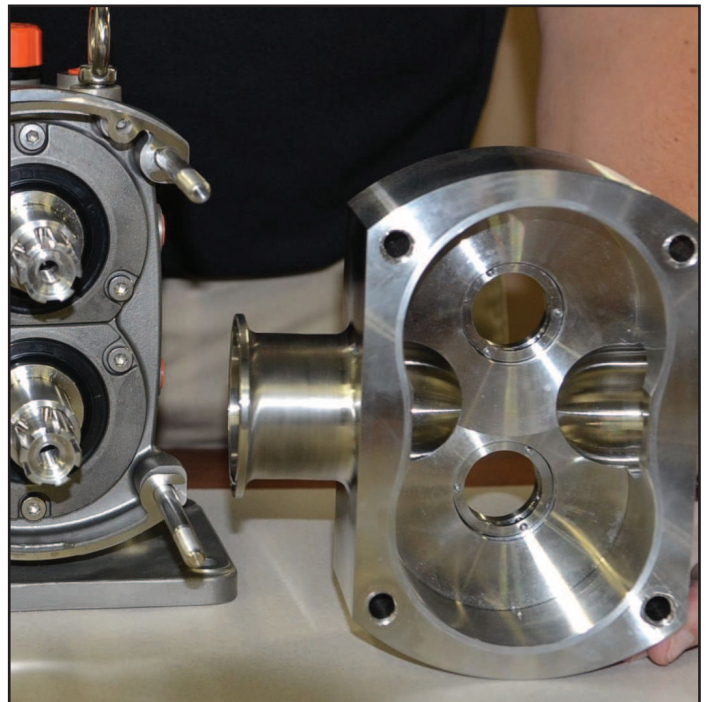
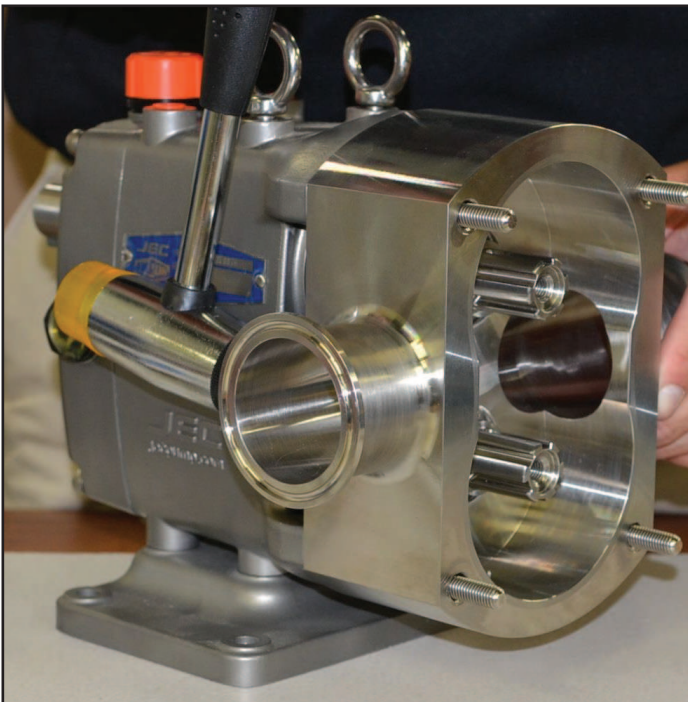

Maintenance

Pump Housing Disassembly - Double Mechanical Seal (continued)

12. Remove the rotor case O-ring (53). This can be done before you remove the casing or after.

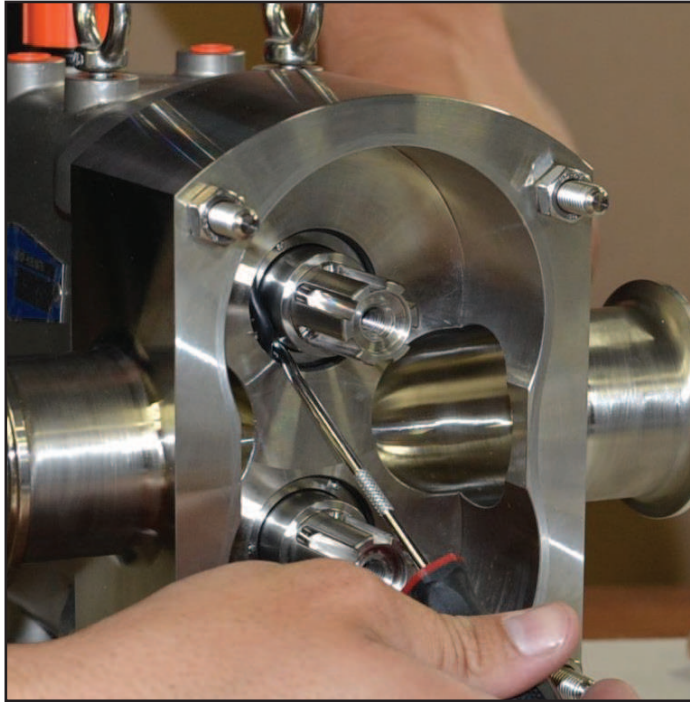

13. Remove seal body case (61) and seal O-ring (62).



Maintenance

Pump Housing Disassembly - Double Mechanical Seal (continued)

14. Remove casing O-ring (53).

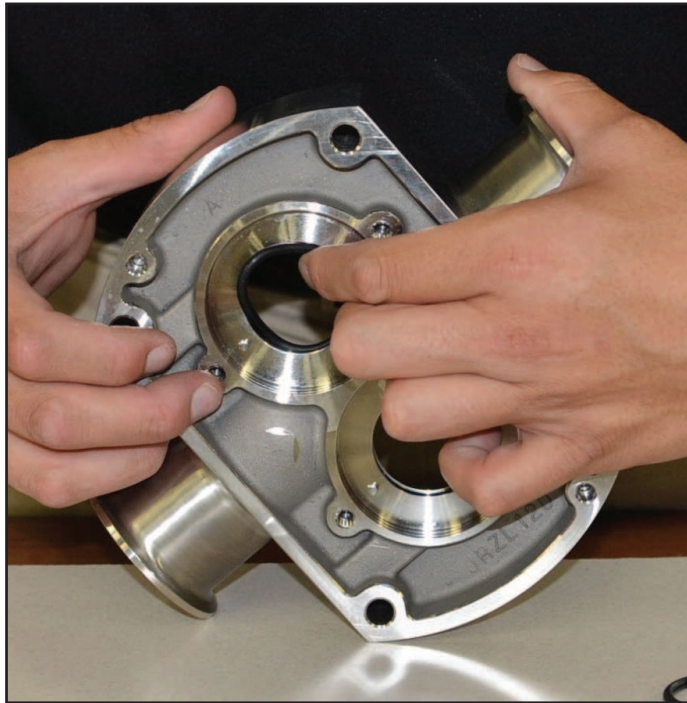

15. Remove shaft seal base (63).

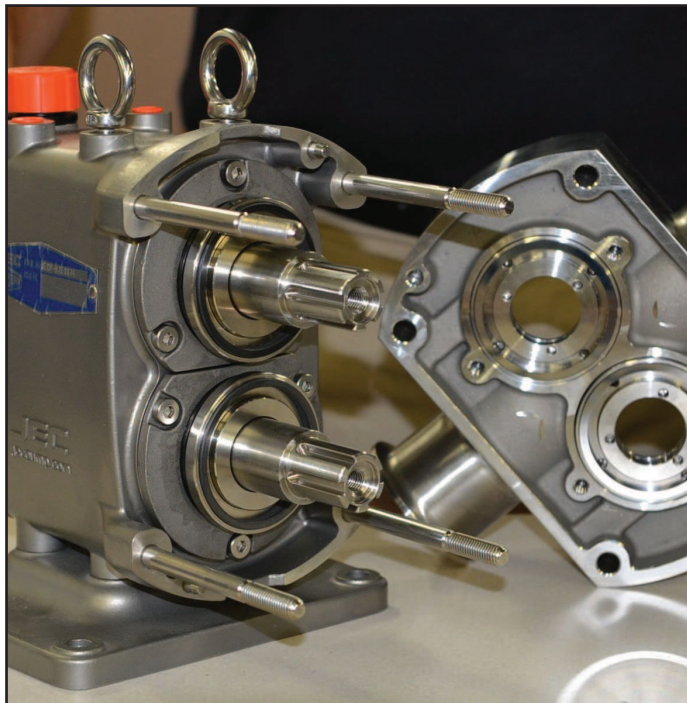

Maintenance

Pump Housing Disassembly - Double Mechanical Seal (continued)

16. Remove shaft O-ring (64).



Maintenance

Pump Housing Disassembly - Single O-ring Seal

! Prior to removal of pump, the shut-off valves in the suction and discharge lines must be closed. If there is any risk that product may harden, crystallize or freeze in the pump it should be thoroughly drained and cleaned immediately after use. Same attention applies if there is a seal flush option. Power needs to be locked out to prevent unintended start of the pump.

Note: Reference numbers are listed in the sectional view located on pages 61-73.

1. Loosen and remove the four hex nuts (33) from the front cover.



2. Remove the cover (32). If it is stuck, tap the cover with a soft hammer.

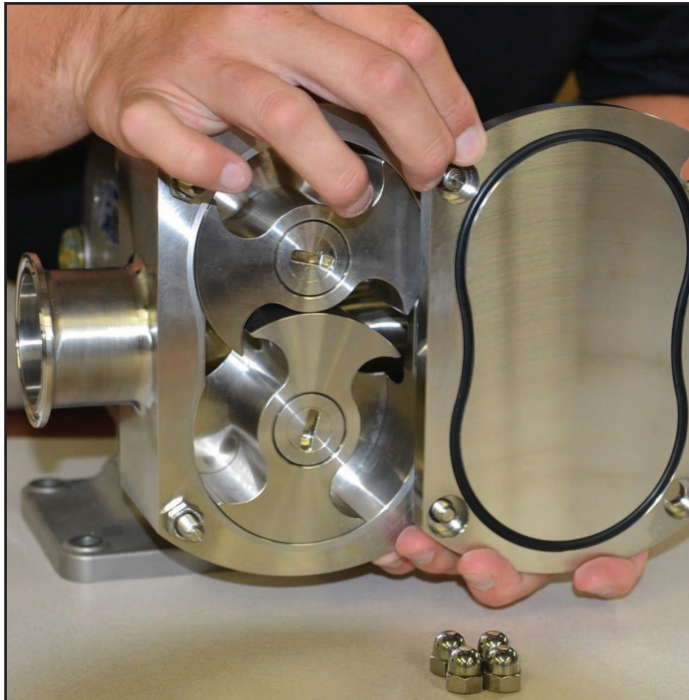

Maintenance

Pump Housing Disassembly - Single O-ring Seal (continued)

3. Remove the cover O-ring (34).

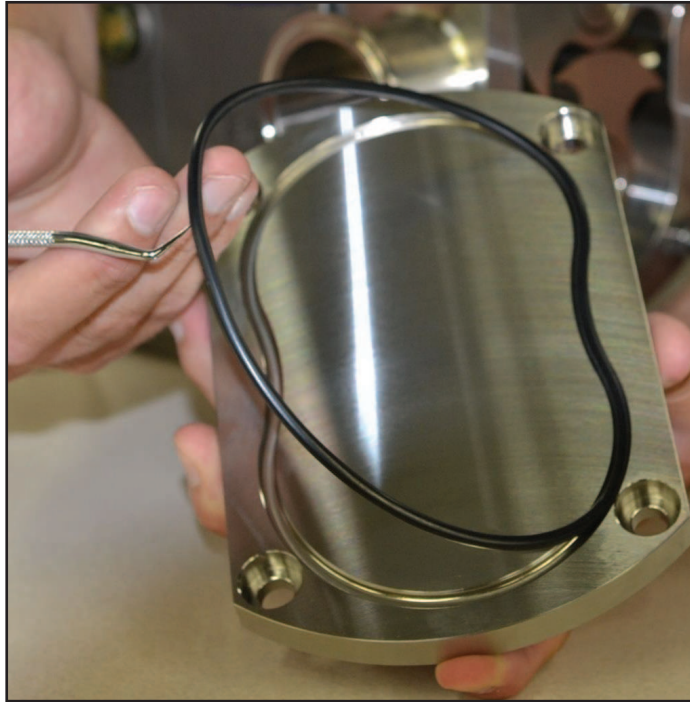

4. Remove the rotor retaining bolts (35). To remove the rotor retaining bolts, place the dowel between the rotors. Turn the first rotor bolt counter-clockwise.

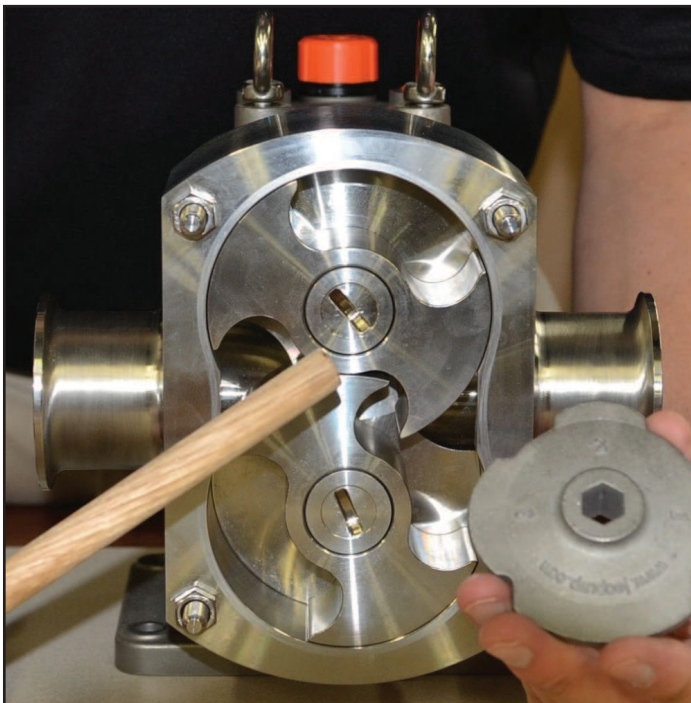

Maintenance

Pump Housing Disassembly - Single O-ring Seal (continued)

5. Remove the rotor bolts (35), spring washers (36) and O-ring (37).



6. Remove the rotors (38) from the pump housing (31) by pulling straight.

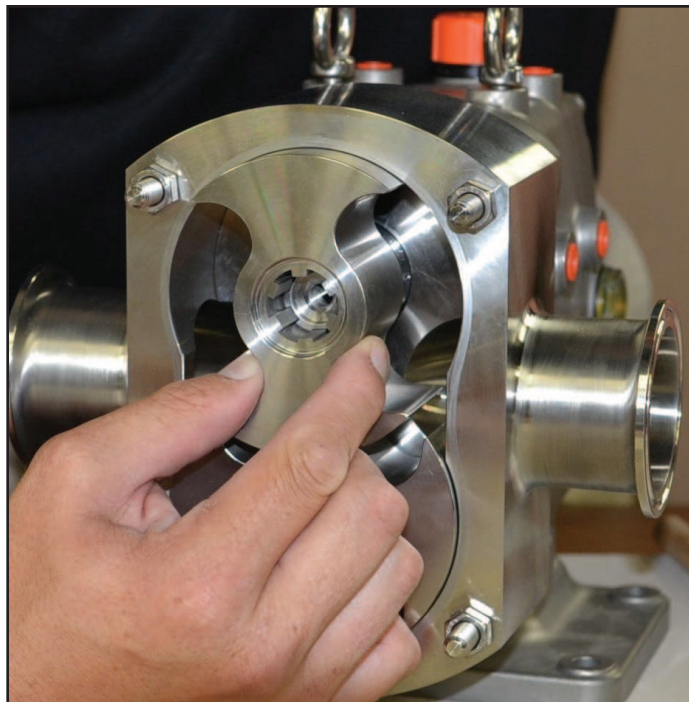

Maintenance

Pump Housing Disassembly - Single O-ring Seal (continued)

6a. If the rotors (38) will not come out freely, remove the stud bolt hex nuts (46) and then tap on the back of the inlet and outlet ports with a soft hammer. Once the rotors (38) are loose, then push the casing (31) back towards the gear box and remove the rotors.

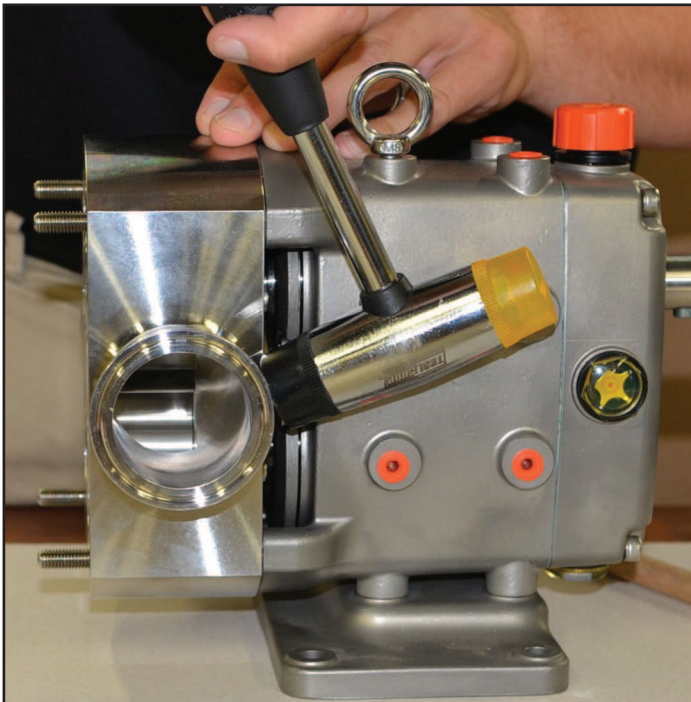
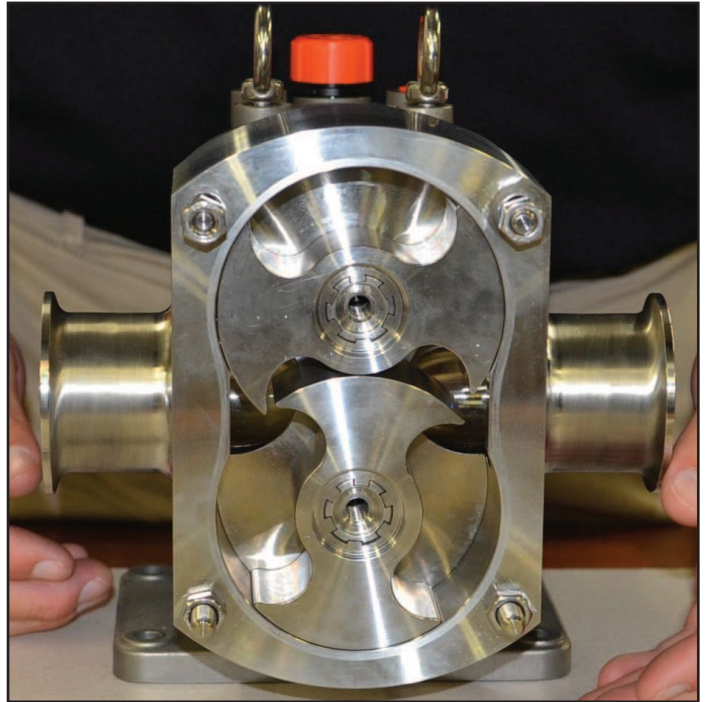

Maintenance

Pump Housing Disassembly - Single O-ring Seal (continued)

6a. continued



7. Remove O-ring (51) from the rotor.



Maintenance

Pump Housing Disassembly - Single O-ring Seal (continued)

8. Remove the rotor case O-ring (53). This can be done before you remove the casing or after. Note: This is easier to do after you remove the casing.

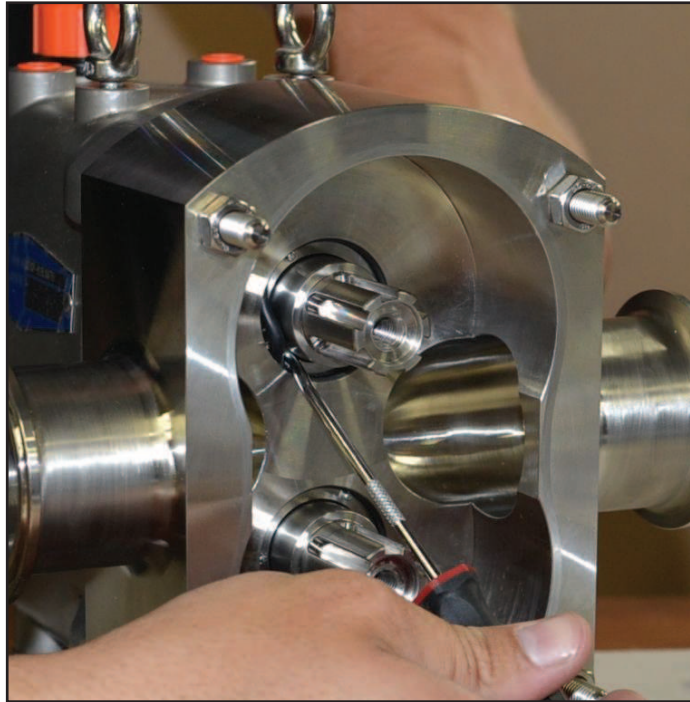

9. Remove sleeve (57) from shaft.

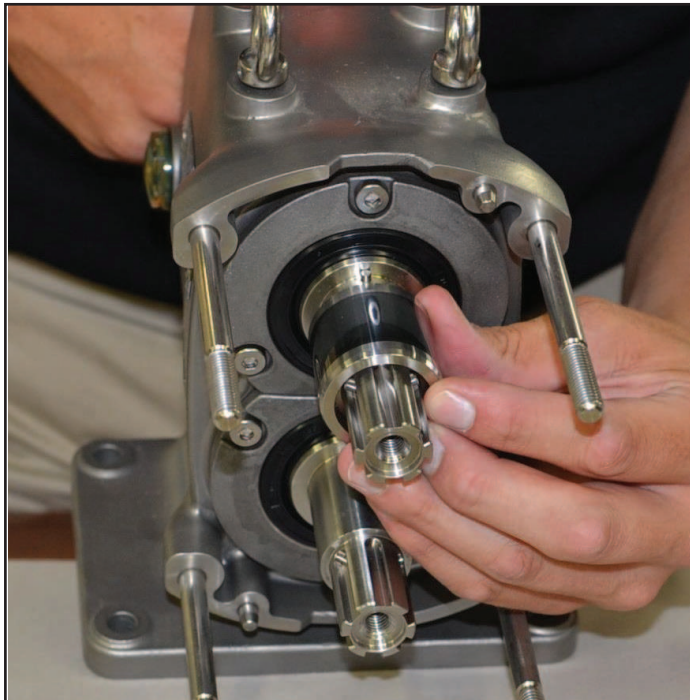

Maintenance

Pump Housing Disassembly - Triple Lip Seal

! Prior to removal of pump, the shut-off valves in the suction and discharge lines must be closed. If there is any risk that product may harden, crystallize or freeze in the pump it should be thoroughly drained and cleaned immediately after use. Same attention applies if there is a seal flush option. Power needs to be locked out to prevent unintended start of the pump.

Note: Reference numbers are listed in the sectional view located on pages 61-73.

1. Loosen and remove the four hex nuts (33) from the front cover.



2. Remove the cover (32). If it is stuck, tap the cover with a soft hammer.

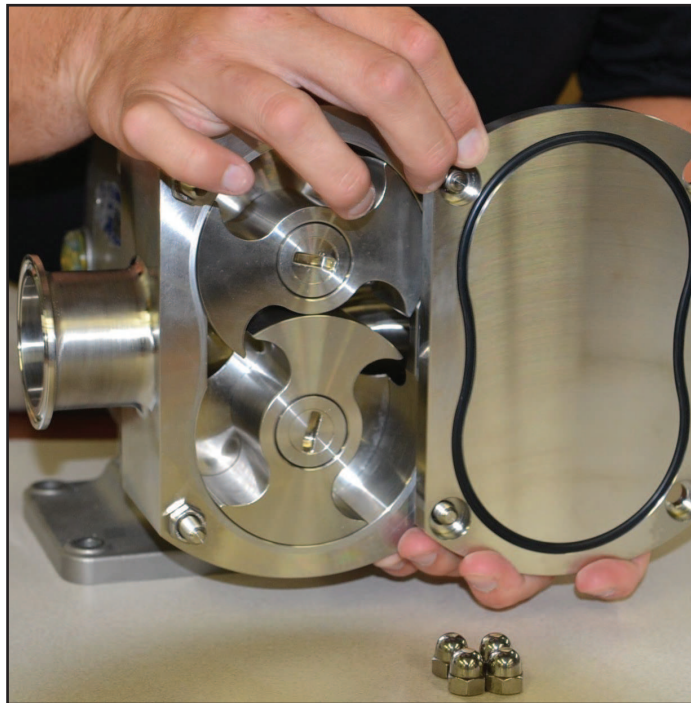

Maintenance

Pump Housing Disassembly - Triple Lip Seal (continued)

3. Remove the cover O-ring (34).

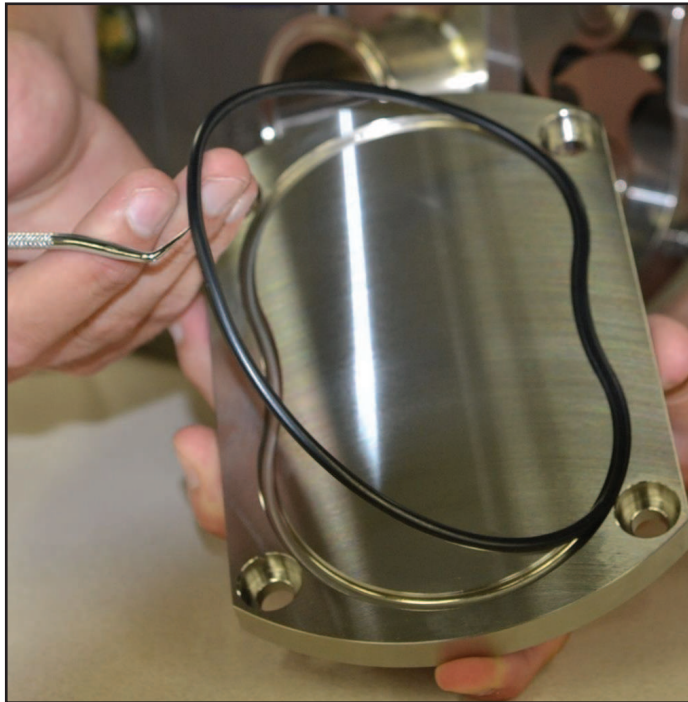

4. Remove the rotor retaining bolts (35). To remove the rotor retaining bolts, place the dowel between the rotors. Turn the first rotor bolt counter-clockwise.

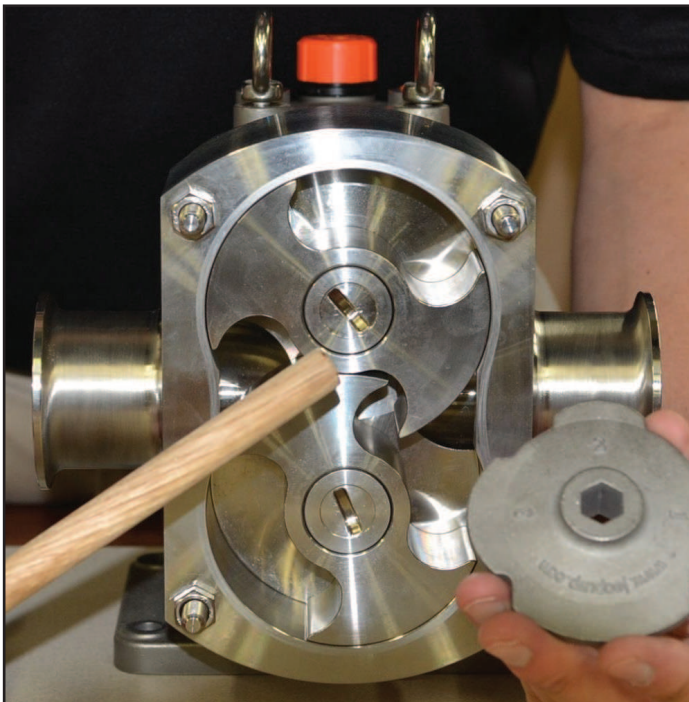

Maintenance

Pump Housing Disassembly - Triple Lip Seal (continued)

5. Remove the rotor bolts (35), spring washers (36) and O-ring (37).

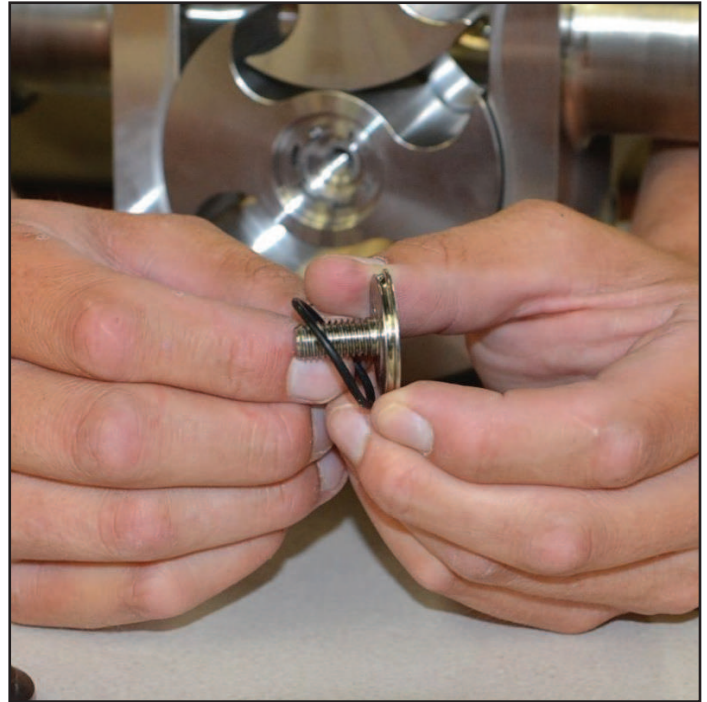

6. Remove the rotors (38) from the pump housing (31) by pulling straight.

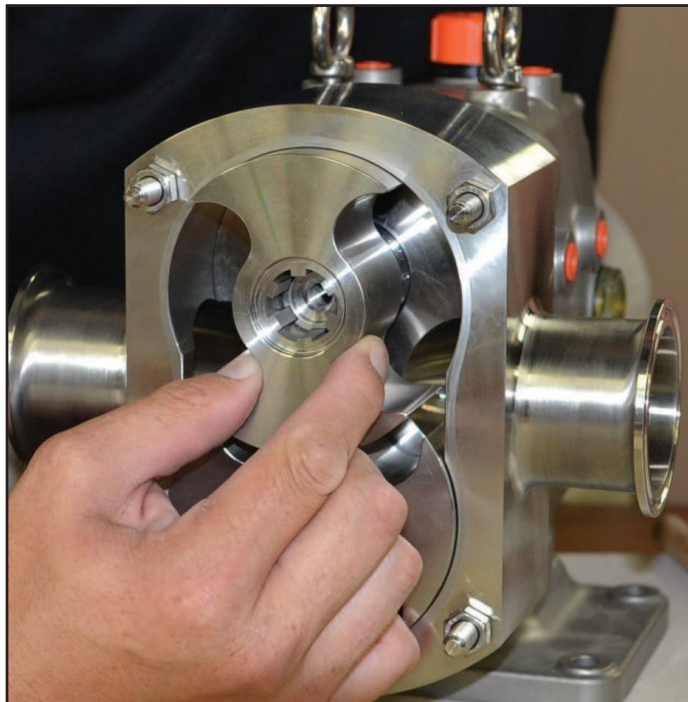

Maintenance

Pump Housing Disassembly - Triple Lip Seal (continued)

6a. If the rotors (38) will not come out freely, remove the stud bolt hex nuts (46) and then tap on the back of the inlet and outlet ports with a soft hammer. Once the rotors (38) are loose, then push the casing (31) back towards the gear box and remove the rotors.

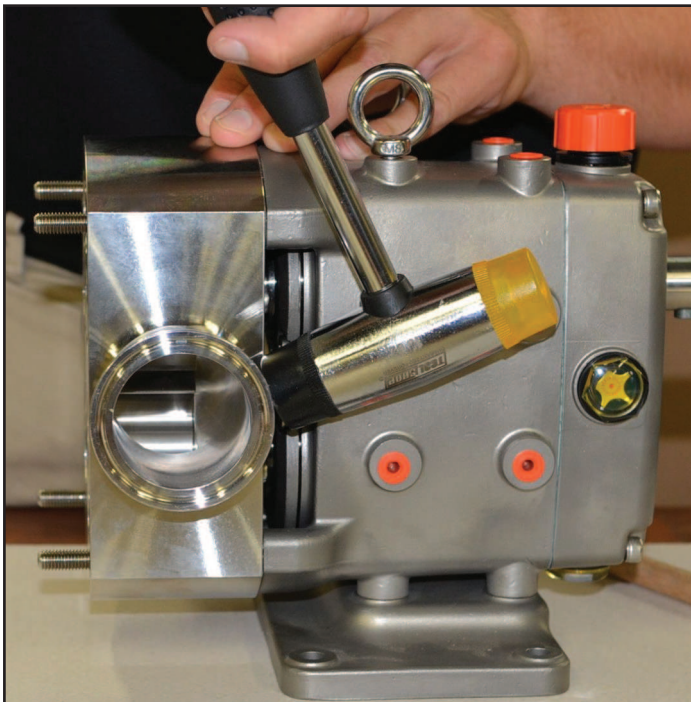
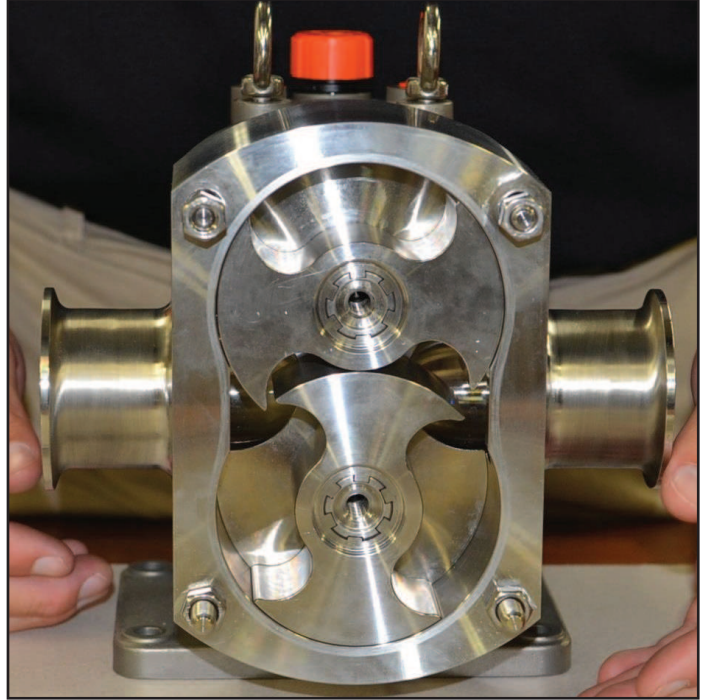

Maintenance

Pump Housing Disassembly - Triple Lip Seal (continued)

6a. continued

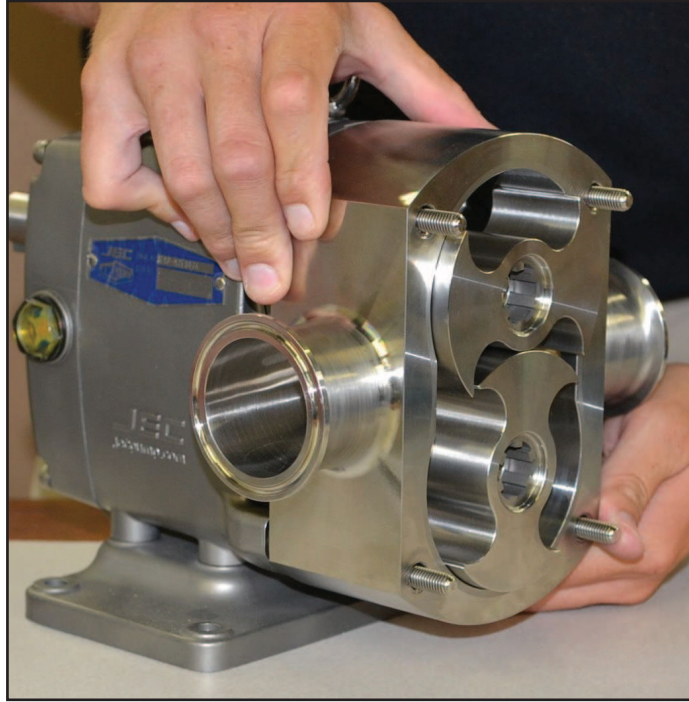

7. Remove O-ring (51) from the rotor.



Maintenance

Pump Housing Disassembly - Triple Lip Seal (continued)

8. Remove lip seal cover (56).

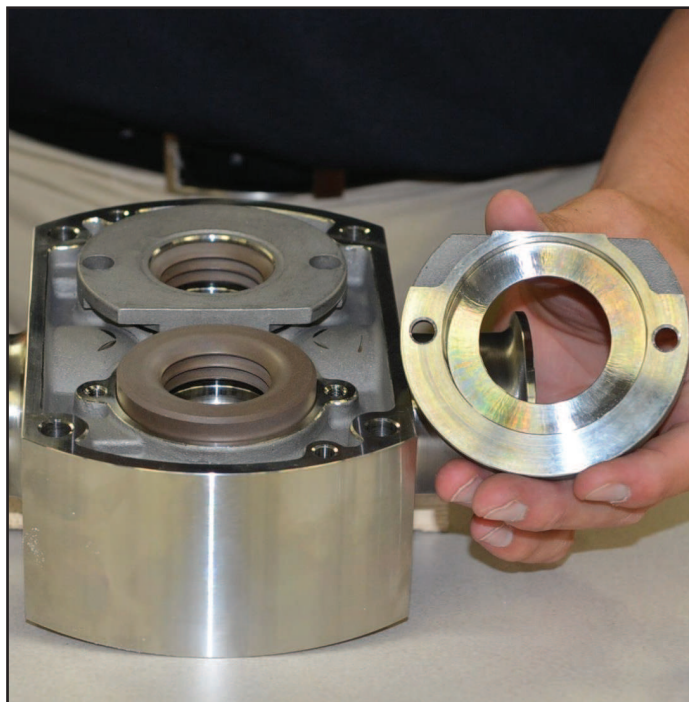
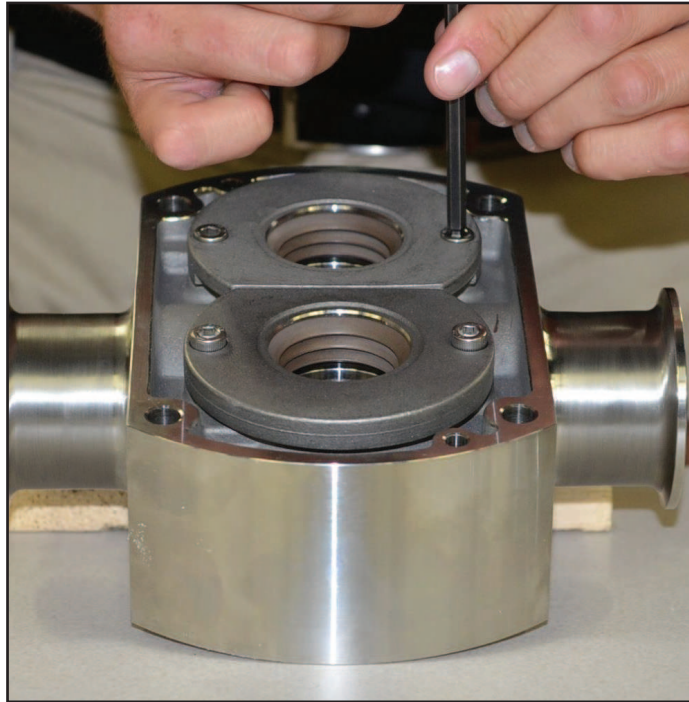

Maintenance

Pump Housing Disassembly - Triple Lip Seal (continued)

9. Remove triple lip seal (55)

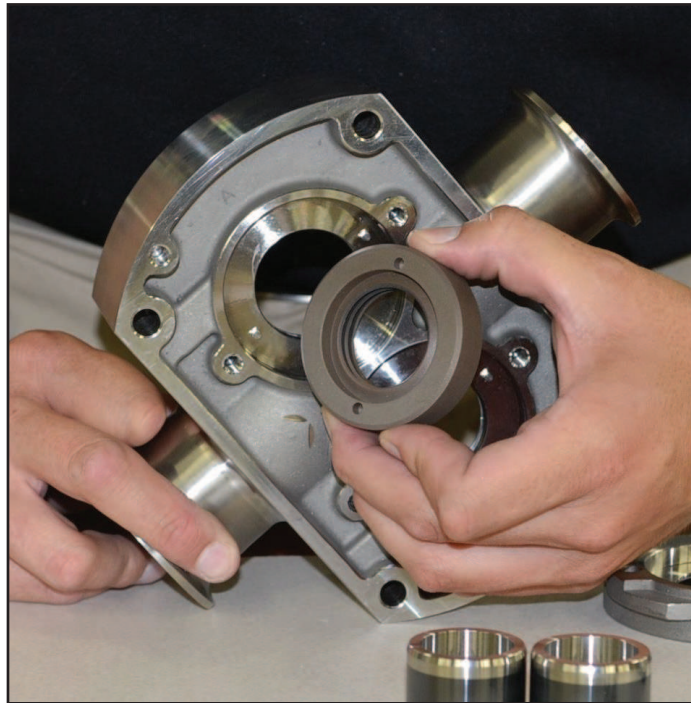

Maintenance

Inspection

1. Inspect O-rings and seals for reuse. Worn O-rings and seals should be replaced.
2. Inspect seal faces for scoring or cracks. Replace any seal faces that are damaged.
3. Inspect rotors for any damage or abnormal wear.
4. Inspect rotors for wear on splines and that they fit snugly on the shafts.
5. Inspect shafts for wear on splines and make sure they are not loose in the gear case.
6. Inspect rotor galling sign among the rotor housing, front cover and rotors. Must be removed or replaced.
7. Inspect burr of the rotor bolt groove. Must be removed or replaced.

Pump Housing Assembly

Before installing the pump housing (31) to the gearbox make sure that the surface of the pump housing and gear box are clean and check the shim plate between pump housing and gear box. Install the pump housing (31) onto the gear box (1A) and secure the four housing set nuts (46).

When installing the ceramic shaft sleeve onto the pump shaft, align sleeve with fit pin.

Follow the disassembly instructions in reverse for all types of seals and rotor assembly.

Assemble a rotor onto shaft engaging the shallow groove with small spline in rotor and seal side first in to the shaft.

Place the plastic dowel between the rotors. Tighten the first rotor bolt with a special tool to the recommended torque.

Model	Rotor Nut Torque Specification
RZL 105	116.3 in. lbs.
RZL 110	116.3 in. lbs.
RZL 115	116.3 in. lbs.
RZL 120	116.3 in. lbs.
RZL 220	277.8 in. lbs.
RZL 225	277.8 in. lbs.
RZL 330	434.0 in. lbs.
RZL 340	434.0 in. lbs.
RZL 440	651.0 in. lbs.
RZL 450	651.0 in. lbs.

To tighten the second rotor place the plastic dowel on the opposite side of the rotor and tighten the second rotor bolt to the proper torque.



Install the cover (32) and tighten the cap nuts (33).

Maintenance

Rotor Clearance

Use feeler gauges to verify the back and radial clearances between the rotors and the housing. A depth gauge should be used to verify the front clearance.

Rotor clearance must be precisely maintained to provide maximum pumping efficiency, prevent contact between rotors, rotor housing and front cover during operation. If pumping efficiency is below expectations or if parts contact has occurred during operation (within rated differential pressure) check rotor clearances and adjust if incorrect.

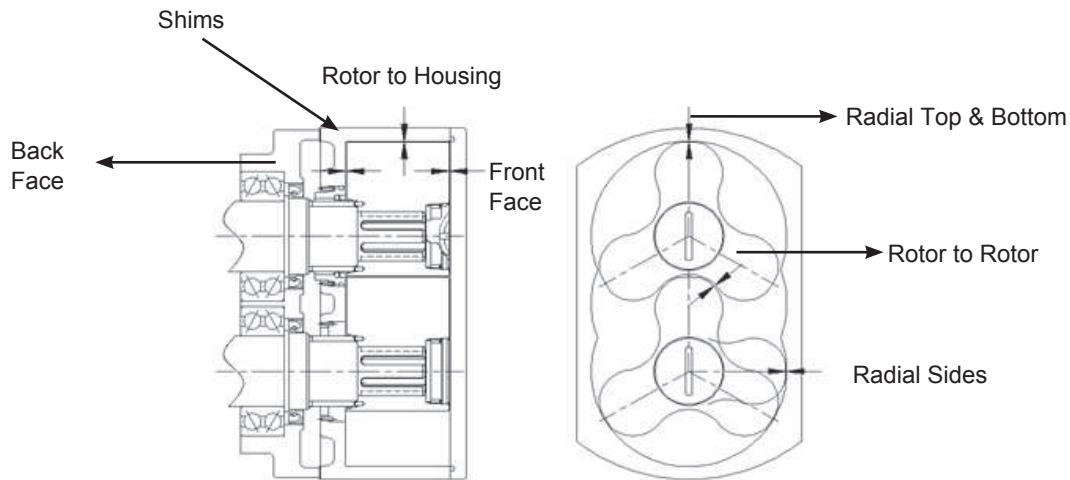

Figure 20

Standard Rotor Clearances (mm/in)

Model	Back Face	Front Face	Radial Sides	Radial Top & Bottom	Rotor to Rotor
RZL 105	0.05/0.002	0.05/0.002	0.07/0.003	0.07/0.003	0.1/0.004
RZL 110	0.05/0.002	0.05/0.002	0.07/0.003	0.07/0.003	0.1/0.004
RZL 115	0.15/0.006	0.15/0.006	0.27/0.011	0.12/0.005	0.15/0.006
RZL 120	0.15/0.006	0.15/0.006	0.3/0.012	0.15/0.006	0.15/0.006
RZL 220	0.2/0.008	0.2/0.008	0.3/0.012	0.15/0.006	0.2/0.008
RZL 225	0.2/0.008	0.2/0.008	0.4/0.016	0.2/0.008	0.2/0.008
RZL 330	0.3/0.012	0.3/0.012	0.4/0.016	0.2/0.008	0.3/0.012
RZL 340	0.3/0.012	0.3/0.012	0.5/0.020	0.3/0.012	0.3/0.012
RZL 440	0.45/0.018	0.45/0.018	0.55/0.022	0.3/0.012	0.4/0.016
RZL 450	0.45/0.018	0.45/0.018	0.7/0.028	0.45/0.018	0.4/0.016

There are two areas of rotor clearances as illustrated following:

- Rotor tip clearance – not adjustable set by manufacturer
- Front and back face clearance – adjustable by shim

Maintenance

Rotor Clearance (continued)

Rotor width and body depth are fixed at manufacturer. Therefore, with the correct rotor size selected, the only maintenance adjustment that can be made is the proportion of front and rear clearance. Measure the front clearance as follows:

1. The rotor to rotor housing back face clearance is maintained by the shim (45).
2. Check that the rotor housing (31) is tight to gearbox (1A). And check the rotor bolts (35) are tight.

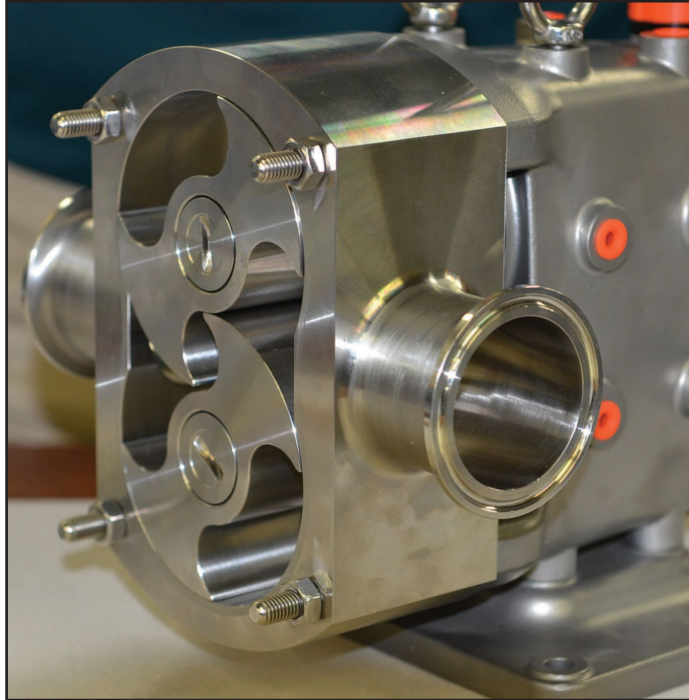

3. Measure the clearance between the back face of the pump housing and the back of the rotor with a feeler gauge. Check the reading with the recommended back face clearance.

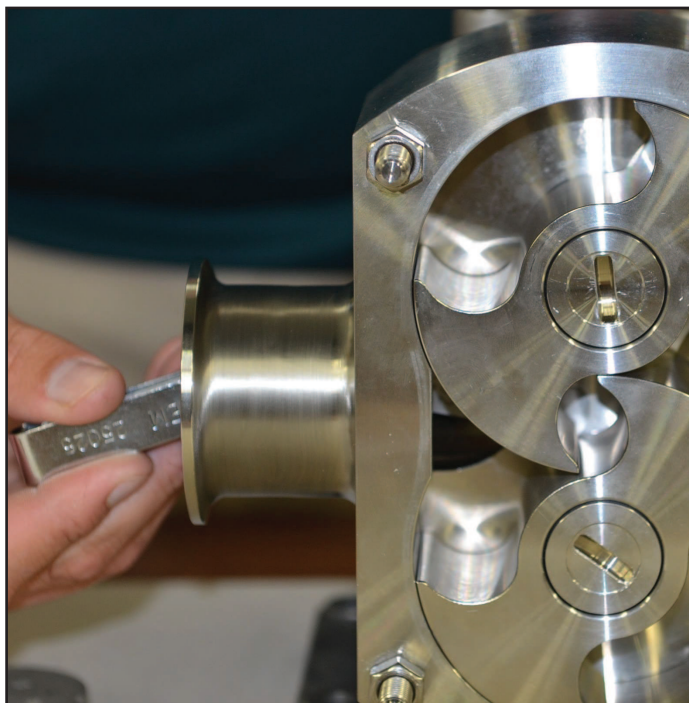

Maintenance

Rotor Clearance (continued)

4. If incorrect, adjust by adding or removing shim plates (45) from behind the pump housing.

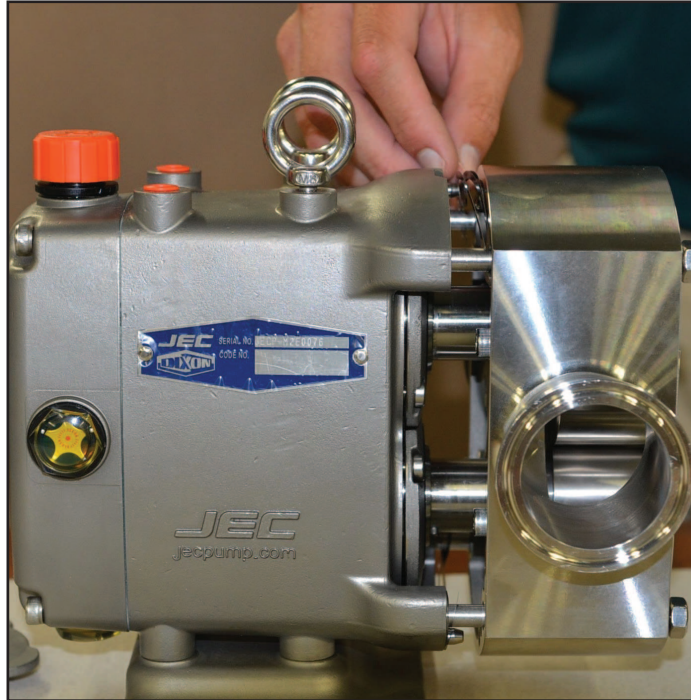

5. Check each rotor and adjust as necessary.

Maintenance

Rotor Timing

Rotor timing must be precisely maintained to provide maximum pumping efficiency, prevent contact between rotors during operation. If pumping efficiency is below expectations or if rotors contact during operation (within rated differential pressure), check rotor timing and adjust if incorrect. Also check rotor timing after any gearbox dismantling when the gears are removed and/or replaced.

Check Rotor timing as follows:

1. Assemble each rotor in its normal location on the drive shaft and the idle shaft. Assemble each rotor bolt and tighten hand tight.
2. Rotate the shafts 30 degrees and measure gap as illustrated by arrows. Rotate the shafts 60 degrees the opposite direction and measure gap as illustrated.
3. The rotors are correctly timed when the gap measured at both locations are equal. If the gap is unequal, adjust the timing as follows.
4. Rotor timing is determined by the relative location of the two helical gears (14) on the shafts. Gear spacers (16) are used to adjust the location and the timing. When adjusting timing, move only one of the two gears.
5. Place the wooden dowel between the rotors.
6. Bend away the tab of the lock washer (12) on one shaft. Loosen the lock nut and temporarily insert shim stock between the gear and gear spacer. Tighten the lock nut, reassemble the rotor in its correct location, and recheck rotor timing.
 - If rotor timing is correct, remove the gear and replace added other spacer or add a shim equal in thickness to the shim stock temporarily added. Reassemble the gear and gear nut, tighten to the correct torque, and check rotor timing again to confirm that it is correct.
 - If rotor timing is incorrect, but closer to equal than original measurement, repeat previous step adding additional shim stock.
 - If rotor timing is incorrect and more unequal than original measurement, remove temporary shim stock from one shaft and add instead to the other shaft.
7. Repeat above procedures until the timing gap is equal after gear spacers are in place and gear nuts are tightened to correct torque.
8. Reassemble pump.

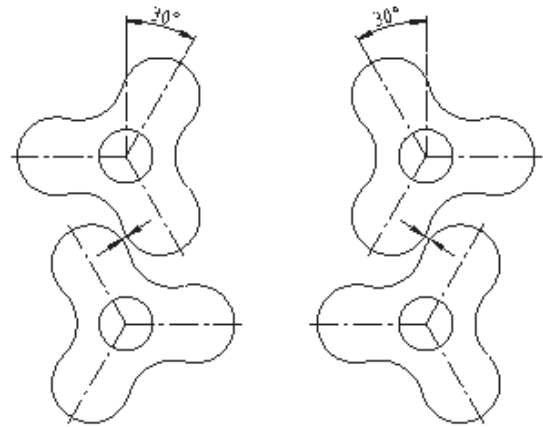

Maintenance

Gearbox Disassembly

1. Remove the oil drain plug and drain the oil.
2. Remove the gear box cover bolts (6) from the rear cover (4).
3. Pull the rear cover off the drive shaft extension. If the cover is stuck use a soft hammer carefully to loosen it.
4. Remove the rear cover oil seal (11) from the rear cover.
5. Remove the paper gasket (26) from the rear cover or gear box.
6. Straighten the locking tab of the bearing lock washer (12). Reinstall the rotors (38) on the drive (8) and idle (9) shafts. Lock the rotor with a plastic dowel. Remove the lock nut (12-1) and lock nut washer from the drive shaft (8) and idle shaft (9).
7. Pull the two helical-gears (14) off the pump shafts. Remove the gear keys (7).
8. Remove the front bearing gland set bolts (23).
9. Place the gearbox (1), wet end (rotor side) down, on an arbor press.
10. Protect the shaft ends with a wood block and press the drive and idle shaft out of the gearbox.
11. Remove the bearings (17) and spacers (18) together by pressing them out from the shafts.
12. Or remove bearings by puller.
13. The taper roller bearings for 400 series must be kept together with in-outside spacer and separated for drive and idle shafts.

Maintenance

Gearbox Assembly

1. Clean and lubricate the front and rear bearing areas of the drive and idle shafts with oil.
2. Fit the front bearing, spacer and rear bearing on the shaft by arbor press or heat 120C (250F) up by heater.
3. Lubricate and install the front bearing oil seals (22) in to the bearing gland.
4. Position the gearbox (1) with wet end up.
5. Clean and lubricate the front and rear bearing areas with oil.
6. Insert the shaft perpendicularly to the gearbox properly. There should be a tight sliding fit between the gearbox and the bearing outer rings. Press or soft hammer could be used.
7. Place the front bearing gland set bolt and washer and tightened.
8. Lubricate and install the rear oil seal cover (24) into gear box (1).
9. Place the gear spacer (16) over the shafts.
10. Clean and lubricate the gear area of the shaft and the face of the lock washer with oil.
11. Position both shaft gear keys (7) to the 12:00 position.
12. Place the gear, lock washer (12) and lock nut (12-1) onto the shafts and hand tighten.
13. After the gears are installed, turn the shafts to make sure they turn freely and that the rotors (38) are timed correctly. (rotor alignments are required)
14. Use a spanner wrench to tighten the gear lock nut on the drive shaft. You can install the rotors to hold the shafts in place while you tighten the nut.
15. Tighten the locknut (12) on the idle shaft, following the previous steps.
16. Install the paper gasket to rear cover (26) and mount the rear cover assembly over the drive shaft extension onto the gearbox.
17. Set the cover bolts, oil window and pressure relieve valve.
18. Fill the oil reservoir with oil to the middle of the oil window.

Scheduled Maintenance

- After initial startup – change oil after 4,000 hours.
- After, change oil annually based on 8 hrs a day, 5 days a week run time.
- Every two years, change oil seals

Recommended Spare Parts:

- 1 Year – (2) Seal sets and (1) O-ring set
- 2 Years – (4) Seal sets and (2) O-ring sets and (1) set rotors

RZL Series Maximum RPM

Viscosity (cP)	Model No. RZL								
	110	115	120	220	225	330	340	440	450
	Recommended Maximum RPM								
1 - 100	1000	800	800	700	700	600	600	500	500
100 - 1,000	667	533	533	467	467	400	400	333	333
1,000 - 5,000	417	333	333	292	292	250	250	208	208
5,000 - 10,000	250	200	200	175	175	150	150	125	125
10,000 - 20,000	167	133	133	117	117	100	100	83	83
20,000 - 50,000	117	93	93	82	82	70	70	58	58
50,000 - 100,000	83	67	67	58	58	50	50	42	42

Note:

1. This maximum RPM speed is calculated and estimated within the ideal operational condition.
2. Pressure, solid(particle), operation hour and other operational conditions effect on this maximum rpm.
3. High RPM is not recommended for pump durability.

Maximum Solids with Bi-Wing Rotors

This is intended to be a guideline only, please contact Dixon Sanitary's Engineering Department to verify specific applications for the best selection of pump and rotor type.

Series No.	Maximum Solid Size (in)
RZL 100	2 x ¾
RZL 200	2½ x 1
RZL 300	3 x 2
RZL 400	5 x 2

The following formulas will also help in determining the best pump and rotor type for applications involving solids in the product.

High Discharge Pressure = Mashed Solid

Low RPM = Increased Possibility of Mashed Solid

Dimensional Drawing

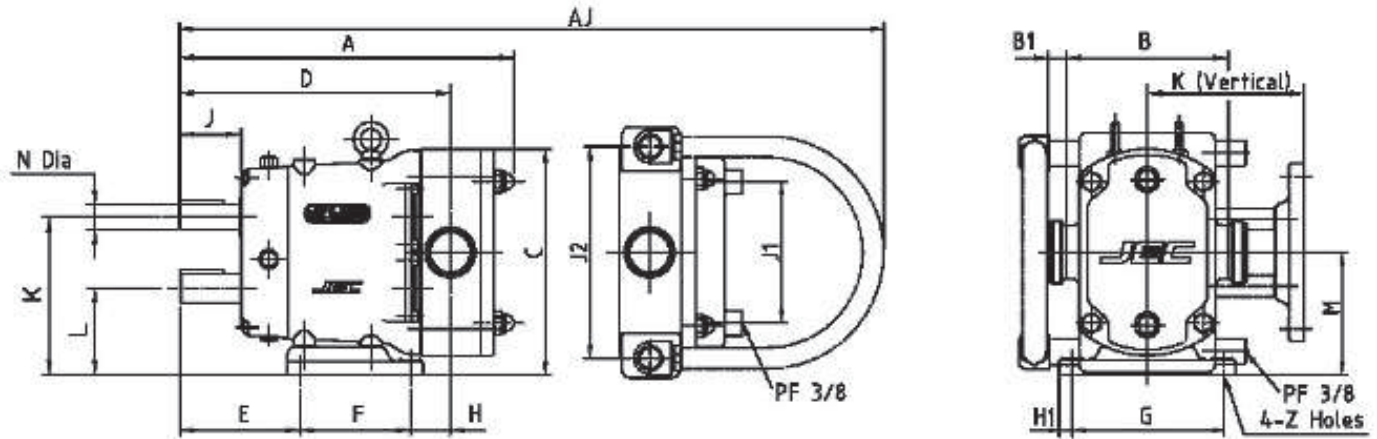

Model	Dimensions (in)																
	A	B	C	D	E	F	G	H	H1 (mm)	J	K	L	M	N (mm)	X ¹ (mm)	Y ² (mm)	Z (mm)
RZL 105	10.40	5.98	7.80	8.62	3.78	3.31	5.28	1.54	12	1.85	5.55	3.03	4.29	22	34	8	9
RZL 110	10.40	5.98	7.68	8.35	3.78	3.31	5.28	1.54	12	1.85	5.55	3.03	4.29	22	34	8	9
RZL 115	10.80	5.98	7.80	8.74	3.78	3.31	5.28	1.65	12	1.85	5.55	3.03	4.29	22	34	8	9
RZL 120	11.42	5.98	7.80	9.02	3.78	3.31	5.28	1.93	12	1.85	5.55	3.03	4.29	22	34	8	9
RZL 220	14.84	7.40	10.12	12.09	5.08	5.20	7.09	1.81	15	2.32	7.28	3.98	5.63	32	53	10	11
RZL 225	15.75	7.40	10.12	12.60	5.08	5.20	7.09	2.13	15	2.32	7.28	3.98	5.63	32	53	10	11
RZL 330	18.70	9.53	13.54	15.32	6.06	6.30	9.53	2.95	22	2.76	9.59	5.06	7.32	45	57	14	13
RZL 340	19.69	9.53	13.54	15.83	6.06	6.30	9.53	3.47	22	2.76	9.59	5.06	7.32	45	57	14	13
RZL 440	24.41	12.76	18.03	19.88	7.80	8.27	12.60	3.94	30	3.15	12.76	6.69	9.72	55	67	14	15
RZL 450	25.79	12.76	18.03	20.55	7.80	8.27	12.60	4.61	30	3.15	12.76	6.69	9.72	55	67	14	15

¹ X = Key Length

² Y = Key Width

Model	Ports	Dimension B1 (in)					AJ	J1	J2	Weight LB
		Clamp	BS	DIN	SMS	FLANGE				
RZL 105	1"	0.79	1.02	0.98	1.10	1.18	16.73	4.80	7.09	37
RZL 110	1"	0.79	1.02	1.18	1.10	1.18	16.73	4.80	7.09	37
RZL 115	1½"	0.87	1.02	1.18	0.79	1.18	16.93	4.80	7.09	42
RZL 120	2"	0.87	1.02	1.18	0.87	1.18	17.32	4.80	7.09	44
RZL 220	2"	0.87	1.02	1.18	0.87	1.18	23.82	6.77	9.25	93
RZL 225	2½"	1.02	1.02	1.46	1.10	1.38	24.80	6.77	9.25	106
RZL 330	3"	1.10	1.02	1.65	1.10	1.57	28.35	9.69	12.13	207
RZL 340	4"	1.10	1.02	1.77	1.38	2.13	29.29	9.69	12.13	227
RZL 440	4"	1.10	1.02	1.77	1.38	2.13	32.68	14.09	16.54	496
RZL 450	5"	1.18	1.02	1.81	1.38	2.13	35.28	14.09	16.54	551

Troubleshooting

Problem	Possible Cause	Suggested Action
No Flow, Pump Rotors Are Not Turning	Drive motor not running.	Check resets, fuses, circuit breakers.
	Key sheared or missing.	Replace.
	Drive belts, power transmission components slipping or broken.	Replace or adjust.
	Pump shaft, keys or gears sheared.	Inspect and replace parts as necessary.
No Flow, Pump Rotors Are Turning	Rotors turning in the wrong direction.	Check motor hookup to reverse motor rotation.
	Relief valve not properly adjusted or held open by foreign material.	Adjust or clear valve.
	Suction port is blocked, not allowing flow to the pump.	Check all inlet valves, strainers and tank outlet ports.
No Flow, Pump Not Priming	Valve closed in inlet line.	Open valve.
	Inlet line clogged or restricted.	Clear line, clean filters, etc.
	Air leaks due to bad gaskets or pipe connections.	Replace gaskets, check lines for leakage (can be done by air pressure or by filing with liquid and pressurizing with air.
	Pump speed too slow.	Increase pump speed.
	Pump speed too fast for high viscosity liquid.	Decrease pump speed.
	Liquid drains or siphons from system during off periods.	Use foot valve or check valves. Filling inlet lines with material before startup may solve startup priming problems due to no material in system.
	"Air" lock caused by fluids which "gas off" or vaporize or allow gas to come out of material during off periods.	Install and use a manual or automatic air bleed from pump or lines near pump.
	Extra clearance rotors, worn pump.	Increase pump speed within limits, use foot valve to improve priming. Replace worn rotors.
	NPSHA too low.	Check net inlet pressure available against net inlet pressure required. Change inlet system as needed.
On "Vacuum" inlet system: On initial start-up, atmospheric "blow back" prevents pump from developing enough differential pressure to start flow.	Install check valve in discharge line.	
Insufficient Flow	Speed too low or too high to obtain desired flow.	Check curve and adjust as necessary.
	Air leak due to bad seals, pipe connections or other equipment.	Replace seals, check inlet fittings.
Insufficient Flow – Flow Being Bypassed Somewhere	Flow diverted in branch line, open valve, etc.	Check system and controls.
	Relief valve not adjusted or jammed.	Clear or adjust valve.
Insufficient Flow – High Slip	Hot (HC) or extra clearance rotors being used on "cold" fluid and/or low viscosity fluid.	Replace with standard clearance rotors.
	Worn pump.	Increase pump speed (within limits). Replace rotors
	High pressure.	Reduce pressure by adjusting system settings or hardware.

Troubleshooting

Problem	Possible Cause	Suggested Action
Cavitation	Strainers, foot valves, inlet fittings or lines clogged.	Clear lines. If problem continues, inlet system may require changing.
	Inlet line size too small, inlet line too long. Too many fittings or valves. Foot valve, strainers too small.	Increase inlet line size. Reduce length, minimize direction and size changes, reduce number of fittings.
	NPSHA too low.	Raise liquid level in source tank to increase net inlet pressure.
		Increase net inlet pressure by raising or pressurizing source tank.
		Select larger pump size with lower net inlet pressure required.
	Fluid viscosity greater than expected.	Reduce pump speed and accept lower flow or change system to reduce line losses.
		Change temperature of product to reduce viscosity.
Fluid temperature higher than expected (vapor pressure higher).	Reduce temperature, reduce speed and accept lower flow or change system to increase net inlet pressure available.	
Noisy Operation	Cavitation	
	High fluid viscosity High vapor pressure fluid High temperature.	Slow down pump, reduce temperature, change system setup.
	NPSHA less than NPSHR.	Increase NPSHA or decrease NPSHR.
	Air or gas in fluid .	
	Leaks in the pump or piping.	Fix leaks.
	Dissolved gas or naturally aerated products.	Minimize discharge pressure (also see "Cavitation" above).
Noisy Operation Caused By Mechanical Problems	Rotor to Body Contact	
	Improper assembly of pump.	Check clearances and adjust shimming.
	Distortion of pump due to improper piping installation.	Change piping installation to eliminate piping stress and distortion on body.
	Pressures required higher than the pump is rated for.	Reduce discharge pressure required.
	Worn bearings.	Rebuild with new bearings and lubricate regularly.
	Rotor to Rotor Contact	
	Loose or incorrectly-timed gears.	Rebuild with new parts. Note: This will cause severe damage.
	Sheared keys.	Rebuild with new parts. Note: This will cause severe damage.
	Worn gear splines.	Rebuild with new parts. Note: This will cause severe damage.
	Drive noise caused by gear trains, chains, couplings or bearings.	Repair or replace drive parts. Check bearings for damage and replace as necessary.

Troubleshooting

Problem	Possible Cause	Suggested Action
Pump Requires Excessive Power (overheats, stalls, high current draw, breakers trip)	Higher than expected viscosity losses.	If within pump rating, increase drive size
	Higher than expected pressures.	Reduce pump speed. Increase line sizes.
	Fluid is colder with a higher viscosity than expected.	Heat fluid, insulate lines or heat trace lines.
	Fluid sets in line and pump during shutdown.	Increase line sizes.
		Insulate lines or heat trace lines.
		Install a "soft start" drive.
Install a recirculating bypass system.		
Flush system with a nonsetting fluid.		
Fluid builds up on pump surfaces.	Replace the pump with more running clearances.	
Short Pump Service Life	Pumping abrasives.	Larger pumps at slower speeds.
	Speeds and pressures higher than rated.	Reduce speeds and pressures by making changes in the system.
		Replace pump with a larger model with higher pressure ratings.
	Worn bearings and gears due to lack of lubrication.	Check and replace bearing and gears as necessary. Adjust lubrications schedule to decrease time between lubrication.
Modify external wash down method to reduce water entering into gear case.		
Misalignment of drive and piping. (Excessive overhung load or misaligned couplings.)	Check alignment of piping and drive. Adjust as necessary.	
Any Other Issue		Contact: Dixon Sanitary 800-789-1718

Parts List for RZL-100 Series Pumps

Basic Assembly (Single M/Seal)

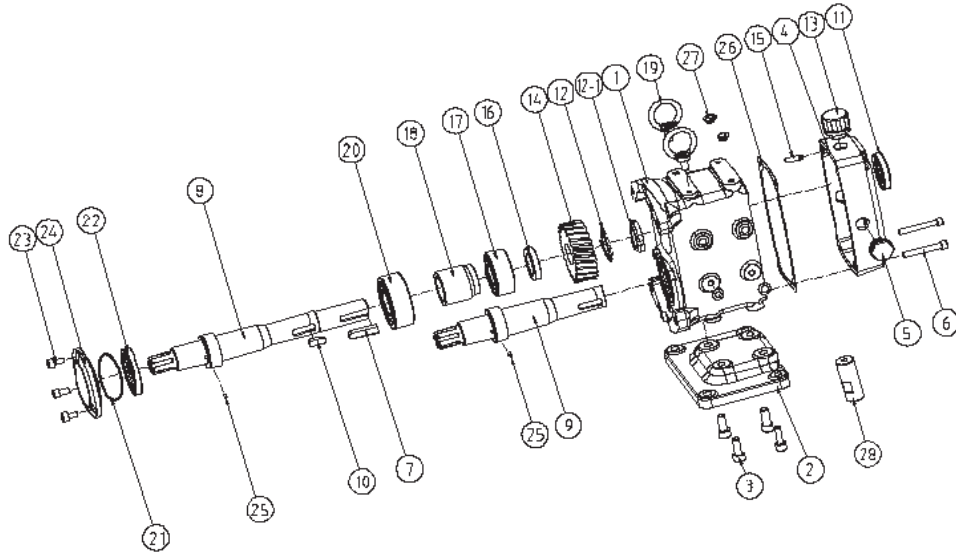
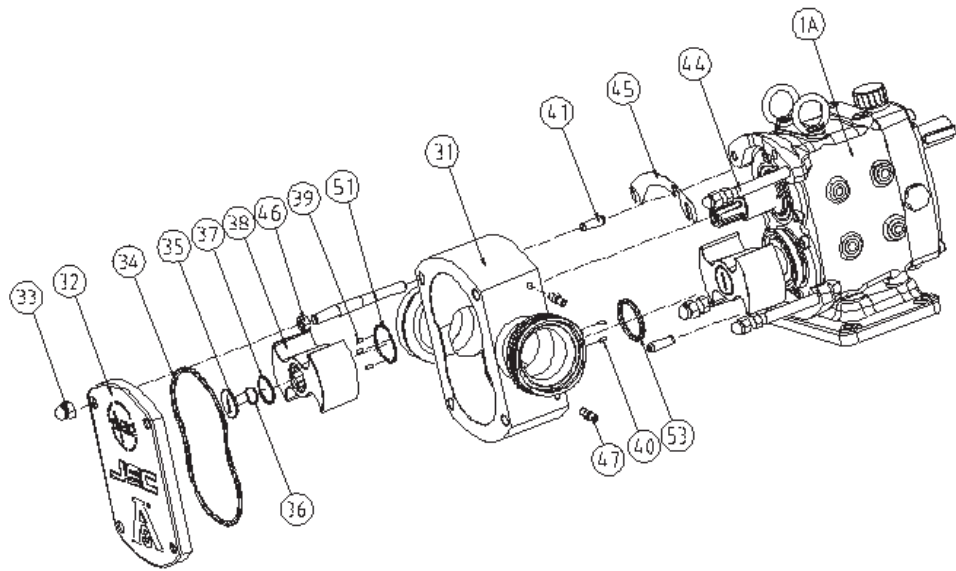

Parts List for RZL-100 Series Pumps

Gear Box Assembly (Basic)

Item	Dixon Sanitary Part #	Description	Material	Used	Quantity	
					Per Assembly	Per Pump
1	RZL-115B-GBCI	Gear Box	FCD40	RZL100	1	1
	RZL-115B-GBCI	Gear Box	SUS304	RZL100	1	1
2	RZL-115B-GBCIB	Base, Gear Box	FCD40	RZL100	1	1
	RZL-115B-GBSSB	Base, Gear Box	SUS304		1	1
	RZL-115B-GBTB	Tripod base, Gear Box	FCD40		1	1
3	RZL-115B-BWB	Wrench Bolt, Base(M8x20L)	SUS304	RZL100	1	4
4	RZL-115B-GBCCI	Cover, Gear Box	FCD40	RZL100	1	1
	RZL-115B-GBCSS	Cover, Gear Box	SUS304		1	1
	RZL-115B-GBCFI	Cover, Gear Box, Flange integrated	FCD40		1	1
5	RZL-115B-PLD	Plug, Level, Drain		RZL100/RZL200	1	3
6	RZL-115B-GBWB	Wrench Bolt, Gear Box Cover (M6x45L)	S45C	RZL100	1	4
7	RZL-115B-DSLEY	Key, Shaft (8x7x34)	S45C		1	1
8	RZL-115-DSHAFT	Shaft, Drive	SUS304	RZL105/110/115	1	1
	RZL-120-DSHAFT	Shaft, Drive	SUS304	RZL120	1	1
9	RZL-115-ISHAFT	Shaft, Idle	SUS304	RZL105/110/115	1	1
	RZL-120-ISHAFT	Shaft, Idle	SUS304	RZL120	1	1
10	RZL-115B-GKEY	Key, Gear (8x7x21)	S45C	RZL100	1	2
11	RZL-115B-OSCB	Oil Seal, Cover(23x43x7t)	NBR	RZL100	1	1
	RZL-115B-OSCV	Oil Seal, Cover(23x43x7t)	FKM		1	1
12	RZL-115B-TGWASH	Lock Washer	S45C		1	2
12-1	RZL-115B-TGNUT	Lock Nut	S45C		1	2
13	RZL-115B-RVLV	Breather, Gearbox	PE	RZL100/RZL200	1	1
14	RZL-115B-TGHELG	Hellical Gear	S45C	RZL100	1	2
15	RZL-115B-GBDOW	Dowel, Gear Box (Φ6)	SUS304	RZL100	1	2
16	RZL-115B-GSPAC	Spacer, Gear (Φ35x5L)	S45C	RZL100/200/300/400	1	2
17	RZL-115B-RBEAR	Bearing, Rear (#5205)			1	2
18	RZL-115B-BSPAC	Spacer, Bearing	S45C		1	2
19	RZL-115B-IBOLT	I-bolt / M8	SUS304		1	2
20	RZL-115B-FBEAR	Bearing, Front (#5206)			1	2
21	RZL-115B-OSGOV	O-ring, Oil seal gland (AN035)	FKM		1	2
22	RZL-115B-OSGB	Oil Seal, Gear Box (38x55x9t)	NBR		1	2
	RZL-115B-OSGV	Oil Seal, Gear Box (38x55x9t)	FKM	1	2	
23	RZL-115B-OSGWB	Wrench Bolt, Oil Seal Gland (M6x12L)	SUS304	RZL100	3	6
24	RZL-115B-OSGLD	Gland, Oil Seal	SUS304	RZL100	1	2
25	RZL-115B-DSPIN	Pin, Double Seal	SUS304		1	2
26	RZL-115B-GCGP	Gasket	Paper		1	1
27	RZL-115B-PLUG	Plug (M8)	PE	RZL100	1	8
28	RZL-115B-VADAPT	Vertical adaptor	SUS304	RZL100	1	4
29	RZL-115B-LFP	Pad, Leg feet	SS+Rubber	RZL Series	1	4
30	RZL-115B-ERT	Rotor tool, Extraction	SUS304	RZL Series	1	1

Parts List for RZL-100 Series Pumps Pump Assembly

Item	Dixon Sanitary Part #	Description	Material	Used	Quantity	
					Per Assembly	Per Pump
1A	RZL-115-GBAW	Gear Box Ass'y - White	FCD40	RZL115/110/105	1	1
	RZL-115-GBAS	Gear Box Ass'y - Silver	FCD40	RZL115/110/105	1	1
	RZL-115-GBASS	Gear Box Ass'y - Stainless Steel	SUS304	RZL115/110/105	1	1
	RZL-120-GBAW	Gear Box Ass'y - White	FCD40	RZL120	1	1
	RZL-120-GBAS	Gear Box Ass'y - Silver	FCD40		1	1
	RZL-120-GBASS	Gear Box Ass'y - Stainless Steel Rotor	SUS304		1	1
31	See page 64	Rotor Case *	SUS316L	RZL100*	1	1
32	RZL-105-FCVVR	Front Cover	SUS316L	RZL105	1	1
	RZL-110-FCVVR	Front Cover	SUS316L	RZL110	1	1
	RZL-115B-RCVVR	Front Cover	SUS316L	RZL115/RZL120	1	1
33	RZL-115B-CNUT	Cap Nut	SUS304	RZL115/RZL120	1	4
34	RZL-105-FCORB	O-ring, Front Cover (AN246)	NBR	RZL105	1	1
	RZL-105-FCORE	O-ring, Front Cover (AN246)	EPDM		1	1
	RZL-105-FCORV	O-ring, Front Cover (AN246)	FKM		1	1
	RZL-105-FCORP	O-ring, Front Cover (AN246)	Perfluoro		1	1
	RZL-105-FCORT	O-ring, Front Cover (AN246)	PTFE capsulated		1	1
	RZL-110-FCORB	O-ring, Front Cover (AN248)	NBR	RZL110	1	1
	RZL-110-FCORE	O-ring, Front Cover (AN248)	EPDM		1	1
	RZL-110-FCORV	O-ring, Front Cover (AN248)	FKM		1	1
	RZL-110-FCORP	O-ring, Front Cover (AN248)	Perfluoro		1	1
	RZL-110-FCORT	O-ring, Front Cover (AN248)	PTFE capsulated	1	1	
	RZL-115B-FCORB	O-ring, Front Cover (AN251)	NBR	RZL115/120	1	1
	RZL-115B-FCORE	O-ring, Front Cover (AN251)	EPDM		1	1
	RZL-115B-FCORV	O-ring, Front Cover (AN251)	FKM		1	1
	RZL-115B-FCORP	O-ring, Front Cover (AN251)	Perfluoro		1	1
RZL-115B-FCORT	O-ring, Front Cover (AN251)	PTFE capsulated	1		1	
35	RZL-115B-RB	Rotor Bolt	SUS316L	RZL100	1	2
36	RZL-115B-RBW	Spring Washer, Rotot Bolt	SUS304	RZL100	1	2
37	RZL-115B-RBORB	O-ring, Rotor Bolt(AN021)	NBR	RZL100	1	2
	RZL-115B-RBORE	O-ring, Rotor Bolt(AN021)	EPDM		1	2
	RZL-115B-RBORV	O-ring, Rotor Bolt(AN021)	FKM		1	2
	RZL-115B-RBORP	O-ring, Rotor Bolt(AN021)	Perfluoro		1	2
	RZL-115B-RBORT	O-ring, Rotor Bolt(AN021)	PTFE capsulated		1	2
38	See page 64	Rotor *	SUS316L	RZL100 *	1	2
39	RZL-115B-RTSLP	Seal pin, Rotor	SUS304	RZL100 *	3	6
40	RZL-115B-CSSLP	Seal pin, Case	SUS304	RZL100 *	2	4
41	RZL-115B-RCDOW	Dowel, Rotor Case (Φ6)	SUS304	RZL100	1	2
44	RZL-105B-CSSB	Stud Bolt, Case (M8)	SUS304	RZL105/110	1	4
	RZL-115-CSSB	Stud Bolt, Case (M8)	SUS304	RZL115	1	4
	RZL-120-CSSB	Stud Bolt, Case (M8)	SUS304	RZL120	1	4
45	RZL-115B-SHIM05	Shim, 0.05mm	SUS304	RZL100	1	2
	RZL-115B-SHIM1	Shim, 0.1mm	SUS304		1	2
46	RZL-115B-SBHYN	Hex nut, Stud Bolt (M8)	SUS304	RZL100	2	4
47	RZL-115B-FSNIP	Nipple, Flush (PT 1/8")	SUS304	RZL100	1	2
48	RZL-115B-NPLT	Name Plate	SUS304	RZL100	1	1
51	RZL-115B-RTORB	O-ring, Rotor (AN028)	NBR	RZL100	1	2
	RZL-115B-RTORE	O-ring, Rotor (AN028)	EPDM		1	2
	RZL-115B-RTORV	O-ring, Rotor (AN028)	FKM		1	2
	RZL-115B-RTORP	O-ring, Rotor (AN028)	Perfluoro		1	2
53	RZL-115B-RCORB	O-ring, Rotor Case (AN220)	NBR	RZL100	1	2
	RZL-115B-RCORE	O-ring, Rotor Case (AN220)	EPDM		1	2
	RZL-115B-RCORV	O-ring, Rotor Case (AN220)	FKM		1	2
	RZL-115B-RCORP	O-ring, Rotor Case (AN220)	Perfluoro		1	2

- Please refer to appendix list for the parts with marked "***"
- Please contact Dixon Sanitary or local distributor for purchased product before 2011 October.
- Rotor case, Front cover, Gear box, Stud bolt, and Shim.

Parts List for RZL-100 Series Pumps

Rotor Case / Rotor

Item	Dixon Sanitary Part #	Description	Material	Used	Quantity	
					Per Assembly	Per Pump
31	RZL-105-RC DIN11	Rotor Case-1"DIN11851	SUS316L	RZL105/110	1	1
	RZL-105-RC DIN26	Rotor Case-1"DIN2633(FRANGE)	SUS316L		1	1
	RZL-105-RCDS	Rotor Case-1"DS722.1	SUS316L		1	1
	RZL-105-RCISO	Rotor Case-1"ISOMALE(IDF)	SUS316L		1	1
	RZL-105-RCRJT	Rotor Case-1"RJT	SUS316L		1	1
	RZL-105-RCSMS	Rotor Case-1"SMS	SUS316L		1	1
	RZL-105-RCCLMP	Rotor Case-1"TRICLAMP	SUS316L		1	1
	RZL-105-RCFLNG	Rotor Case-1"FLANGE	SUS316L		1	1
31	RZL-115-RC DIN11	Rotor Case-1.5"DIN11851	SUS316L	RZL115	1	1
	RZL-115-RC DIN26	Rotor Case-1.5"DIN2633(FRANGE)	SUS316L		1	1
	RZL-115-RCDS	Rotor Case-1.5"DS722.1	SUS316L		1	1
	RZL-115-RCISO	Rotor Case-1.5"ISOMALE(IDF)	SUS316L		1	1
	RZL-115-RCRJT	Rotor Case-1.5"RJT	SUS316L		1	1
	RZL-115-RCSMS	Rotor Case-1.5"SMS	SUS316L		1	1
	RZL-115-RCCLMP	Rotor Case-1.5"TRICLAMP	SUS316L		1	1
	RZL-115-RCFLNG	Rotor Case-1.5"FLANGE	SUS316L		1	1
31	RZL-120-RC DIN11	Rotor Case-2"DIN11851	SUS316L	RZL120	1	1
	RZL-120-RC DIN26	Rotor Case-2"DIN2633(FRANGE)	SUS316L		1	1
	RZL-120-RCDS	Rotor Case-2"DS722.1	SUS316L		1	1
	RZL-120-RCISO	Rotor Case-2"ISOMALE(IDF)	SUS316L		1	1
	RZL-120-RCRJT	Rotor Case-2"RJT	SUS316L		1	1
	RZL-120-RCSMS	Rotor Case-2"SMS	SUS316L		1	1
	RZL-120-RCCLMP	Rotor Case-2"TRICLAMP	SUS316L		1	1
	RZL-120-RCFLNG	Rotor Case-2"FLANGE	SUS316L		1	1
38	RZL-105-MLA	Rotor, Multi-Lobe	SUS316L	RZL105	1	2
	RZL-105-MLARV	Rotor, Multi-Lobe, Relief Valve	SUS316L	RZL105	1	2
	RZL-110-BWA	Rotor, Bi-Wing	SUS316L	RZL110	1	2
	RLZ-110-BWARV	Rotor, Bi-Wing, Relief Valve	SUS316L		1	2
	RZL-110-BWTIA	Rotor, Bi-Wing, PTFE-Inserted	SUS316L/PTFE		1	2
	RZL-110-HWA	Rotor, Bi-Wing, high temp clearance	SUS316L		1	2
	RZL-110-MLA	Rotor, Multi-Lobe	SUS316L	RZL115	1	2
	RZL-115-SWA	Rotor, Single-Wing	SUS316L		1	2
	RZL-115-BWA	Rotor, Bi-Wing	SUS316L		1	2
	RZL-115-BWTIA	Rotor, Bi-Wing PTFE-Inserted	SUS316L/PTFE		1	2
	RZL-115-HWA	Rotor, Bi-Wing, high temp clearance	SUS316L		1	2
	RZL-115-BLA	Rotor, Bi-Lobe	SUS316L		1	2
	RZL-115-3LA	Rotor, Tri-Lobe	SUS316L		1	2
	RZL-115-H3LA	Rotor, Tri-Lobe, high temp clearance	SUS316L		1	2
	RZL-115-HELIA	Rotor, Heli-Lobe	SUS316L	1	2	
	RZL-115-MLA	Rotor, Multi-Lobe	SUS316L	1	2	
	RZL-120-SWA	Rotor, Single-Wing	SUS316L	RZL120	1	2
	RZL-120-BWA	Rotor, Bi-Wing	SUS316L		1	2
	RZL-120-BWTIA	Rotor, Bi-Wing PTFE-Inserted	SUS316L/PTFE		1	2
	RZL-120-HWA	Rotor, Bi-Wing, high temp clearance	SUS316L		1	2
	RZL-120-BLA	Rotor, Bi-Lobe	SUS316L		1	2
	RZL-120-3LA	Rotor, Tri-Lobe	SUS316L		1	2
	RZL-120-H3LA	Rotor, Tri-Lobe, high temp clearance	SUS316L		1	2
	RZL-120-HELIA	Rotor, Heli-Lobe	SUS316L		1	2
RZL-120-MLA	Rotor, Multi-Lobe	SUS316L	1		2	
RZL-120-RHELIA	Rotor, Heli-Lobe	EPDM	1		2	

- All standard rotor case don't have tap holes for flushing and jackets

Parts List for RZL-100 Series Pumps

Triple Lip Seal

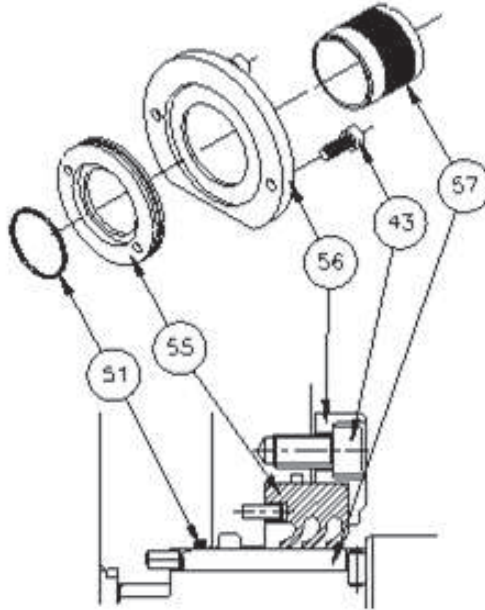

Item	Dixon Sanitary Part #	Description	Material	Used	Quantity	
					Per Assembly	Per Pump
	RZL-115B-3E-KIT	Triple Lip Seal Repair Kit	EPDM	RZL100	1	2
	RZL-115B-3V-KIT	Triple Lip Seal Repair Kit	FKM		1	2
43	RZL-115B-MSGWB	Wrench Bolt, M/Seal Gland (M6x10L)	SUS304	RZL100	2	4
51	RZL-115B-RTORB	O-ring, Rotor (AN028)	NBR		1	2
	RZL-115B-RTORE	O-ring, Rotor (AN028)	EPDM		1	2
	RZL-115B-RTORV	O-ring, Rotor (AN028)	FKM		1	2
	RZL-115B-RTORP	O-ring, Rotor (AN028)	Perfluoro		1	2
56	RZL-115B-LSC	Lip Seal Cover	SUS304		1	2
55	RZL-115B-TRPLSC	Triple Lip Seal, Product	PTFE+Copper		1	2
	RZL-115B-TRPLS	Triple Lip Seal, Product	PTFE+Glass		1	2
57	RZL-115B-CERCS	Ceramic Coated Sleeve, Product	Ceramic/SUS304	1	2	

- Repair kits include items 51, 55, 56 & 57

Parts List for RZL-100 Series Pumps Single Mechanical Seal

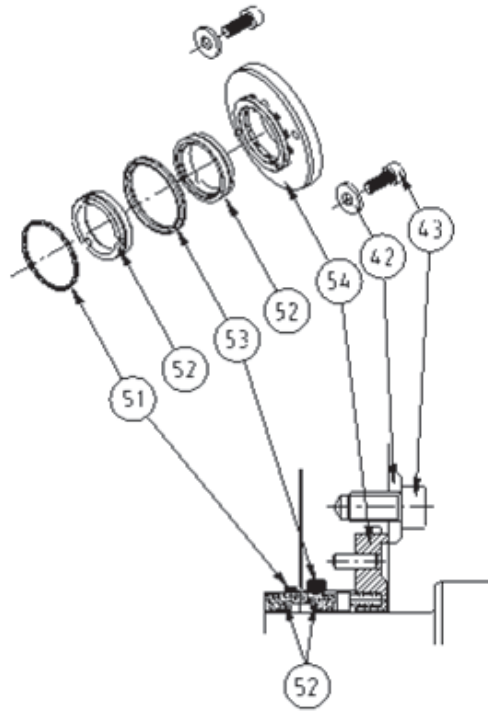

Item	Dixon Sanitary Part #	Description	Material	Used	Quantity		
					Per Assembly	Per Pump	
	RZL-115B-2E-KIT	Single Mech. Seal Repair Kit Kit TC/TC	EPDM	RZL100	1	2	
	RZL-115B-2V-KIT	Single Mech. Seal Repair Kit Kit TC/TC	FKM		1	2	
42	RZL-115B-MSGFW	Flat Washer, M/Seal Gland (Φ6)	SUS304	RZL100	2	4	
43	RZL-115B-MSGWB	Wrench Bolt, M/Seal Gland (M6x10L)	SUS304		2	4	
51	RZL-115B-RTORB	O-ring, Rotor (AN028)	NBR		1	2	
	RZL-115B-RTORE	O-ring, Rotor (AN028)	EPDM		1	2	
	RZL-115B-RTORV	O-ring, Rotor (AN028)	FKM		1	2	
	RZL-115B-RTORP	O-ring, Rotor (AN028)	Perfluoro		1	2	
52	RZL-115B-TCSEAL	Seal Ring	TC		2	4	
	RZL-115B-SCSEAL	Seal Ring	SiC		2	4	
	RZL-120-RHLTCSR	Seal Ring, Rubber Heli-lobe	TC		RZL120	2	4
	RZL-120-RHLSCSR	Seal Ring, Rubber Heli-lobe	SiC			2	4
53	RZL-115B-RCORB	O-ring, Rotor Case (AN220)	NBR	RZL100	1	2	
	RZL-115B-RCORE	O-ring, Rotor Case (AN220)	EPDM		1	2	
	RZL-115B-RCORV	O-ring, Rotor Case (AN220)	FKM		1	2	
	RZL-115B-RCORP	O-ring, Rotor Case (AN220)	Perfluoro		1	2	
54	RZL-115B-CSSB	Single Seal Body, Case	SUS304	1	2		
	RZL-115-CSSB20	Single Seal Body, Case (w/20 springs)	SUS304	1	2		

- Repair kits include items 51, 52, 53 & 54

Parts List for RZL-100 Series Pumps Double Mechanical Seal

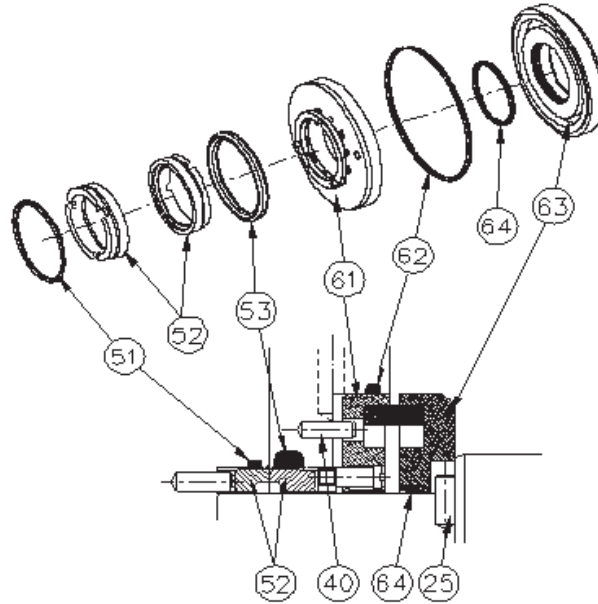

Item	Dixon Sanitary Part #	Description	Material	Used	Quantity	
					Per Assembly	Per Pump
	RZL-115B-4E-KIT	Double Mech. Seal Repair Kit TC/TC	EPDM	RZL100	1	2
	RZL-115B-4V-KIT	Double Mech. Seal Repair Kit TC/TC	FKM	RZL100	1	2
51	RZL-115B-RTORB	O-ring, Rotor (AN028)	NBR	RZL100	1	2
	RZL-115B-RTORE	O-ring, Rotor (AN028)	EPDM		1	2
	RZL-115B-RTORV	O-ring, Rotor (AN028)	FPM		1	2
	RZL-115B-RTORP	O-ring, Rotor (AN028)	Perfluoro		1	2
52	RZL-115B-TCSEAL	Seal Ring	TC	RZL100	2	4
	RZL-115B-SCSEAL	Seal Ring	SIC		2	4
	RZL-120-RHLTCSR	Seal Ring, Rubber Heli-lobe	TC		2	4
	RZL-120-RHLSCSR	Seal Ring, Rubber Heli-lobe	SiC		2	4
53	RZL-115B-RCORB	O-ring, Rotor Case (AN220)	NBR	RZL100	1	2
	RZL-115B-RCORE	O-ring, Rotor Case (AN220)	EPDM		1	2
	RZL-115B-RCORV	O-ring, Rotor Case (AN220)	FKM		1	2
	RZL-115B-RCORP	O-ring, Rotor Case (AN220)	Perfluoro		1	2
61	RZL-115B-CDSBTC	Double Seal Body, Case	TC/SUS304	RZL100	1	2
	RZL-115B-CDSBSC	Double Seal Body, Case	SiC/SUS304		1	2
	RZL-115B-CDHPTC	Double Seal Body, Case, High pressure	TC/SUS304		1	2
	RZL-115B-CDHPTSC	Double Seal Body, Case, High pressure	SiC/SUS304		1	2
62	RZL-115B-CORDSB		NBR	RZL100	1	2
	RZL-115B-CORDSE	O-ring, Case, Double seal (AN036)	EPDM		1	2
	RZL-115B-CORDSV	O-ring, Case, Double seal (AN036)	FKM		1	2
	RZL-115B-CORDSP	O-ring, Case, Double seal (AN036)	Perfluoro		1	2
63	RZL-115B-SDSBC	Rotation part, Double Seal, Shaft	Carbon/SUS304	RZL100	1	2
	RZL-115B-SDSB	Rotation part, Double Seal, Shaft	TC/SUS304		1	2
64	RZL-115B-SORDSB	O-ring, Shaft, Double Seal (AN023)	NBR	RZL100	1	2
	RZL-115B-SORDSE	O-ring, Shaft, Double Seal (AN023)	EPDM		1	2
	RZL-115B-SORDSV	O-ring, Shaft, Double Seal (AN023)	FKM		1	2
	RZL-115B-SORDSP	O-ring, Shaft, Double Seal (AN023)	Perfluoro		1	2

• Repair kits include items 51, 52, 53, 61, 62, 63 & 64.

Parts List for RZL-100 Series Pumps Single O-ring Seal

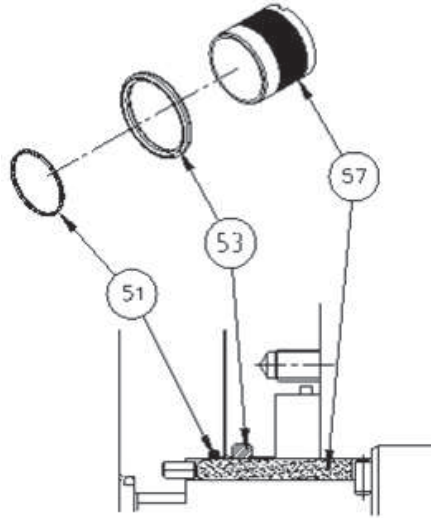

Item	Dixon Sanitary Part #	Description	Material	Used	Quantity	
					Per Assembly	Per Pump
	RZL-115B-1E-KIT	Single O-ring Seal Repair Kit	EPDM	RZL100	1	2
	RZL-115B-1V-KIT	Single O-ring Seal Repair Kit	FKM		1	2
42	RZL-115B-MSGFW	Flat Washer, Seal Gland (Φ6)	SUS304	RZL100	2	4
43	RZL-115B-MSGWB	Wrench Bolt, Gland (M6x10L)	SUS304		2	4
51	RZL-115B-RTORB	O-ring, Rotor (AN028)	NBR		1	2
	RZL-115B-RTORE	O-ring, Rotor (AN028)	EPDM		1	2
	RZL-115B-RTORV	O-ring, Rotor (AN028)	FKM		1	2
	RZL-115B-RTORP	O-ring, Rotor (AN028)	Perfluoro		1	2
53	RZL-115B-RCORB	O-ring, Rotor Case (AN220)	NBR		1	2
	RZL-115B-RCORE	O-ring, Rotor Case (AN220)	EPDM		1	2
	RZL-115B-RCORV	O-ring, Rotor Case (AN220)	FKM		1	2
	RZL-115B-RCORP	O-ring, Rotor Case (AN220)	Perfluoro		1	2
57	RZL-115B-CERCS	Ceramic Coated Sleeve Product	Ceramic/SUS304	1	2	

- Repair kits include items 51, 53 & 57

Parts List for RZL-100 Series Pumps Double O-ring Seal

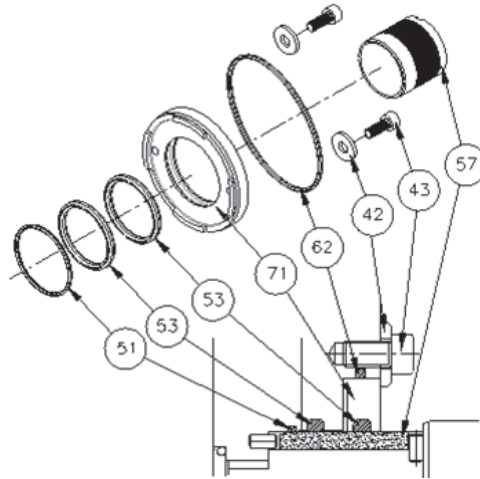

Item	Dixon Sanitary Part #	Description	Material	Used	Quantity	
					Per Assembly	Per Pump
	RZL-115B-5E-KIT	Double O-ring Seal Repair Kit	EPDM	RZL100	1	2
	RZL-115B-5V-KIT	Double O-ring Seal Repair Kit	FKM		1	2
42	RZL-115B-MSGFW	Flat Washer, Seal Gland (Φ6)	SUS304	RZL100	2	4
43	RZL-115B-MSGWB	Wrench Bolt, Gland (M6x10L)	SUS304		2	4
51	RZL-115B-RTORB	O-ring, Rotor (AN028)	NBR		1	2
	RZL-115B-RTORE	O-ring, Rotor (AN028)	EPDM		1	2
	RZL-115B-RTORV	O-ring, Rotor (AN028)	FKM		1	2
	RZL-115B-RTORP	O-ring, Rotor (AN028)	Perfluoro		1	2
53	RZL-115B-RCORB	O-ring, Rotor Case (AN220)	NBR		1	2
	RZL-115B-RCORE	O-ring, Rotor Case (AN220)	EPDM		1	2
	RZL-115B-RCORV	O-ring, Rotor Case (AN220)	FKM		1	2
	RZL-115B-RCORP	O-ring, Rotor Case (AN220)	Perfluoro		1	2
57	RZL-115B-CERCS	Ceramic Coated Sleeve Product	Ceramic/SUS304		1	2
62	RZL-115B-CORDSB	O-ring, Case, Double Seal(AN036)	NBR		1	2
	RZL-115B-CORDSE	O-ring, Case, Double Seal(AN036)	EPDM		1	2
	RZL-115B-CORDSV	O-ring, Case, Double Seal(AN036)	FKM		1	2
	RZL-115B-CORDSP	O-ring, Case, Double Seal(AN036)	Perfluoro		1	2
71	RZL-115B-BDORS	Body, Double O-ring Seal	SUS304		1	2

- Repair kits include items 51, 53, 57, 62 & 71

Parts List for RZL-100 Series Pumps Flushed Mechanical Seal

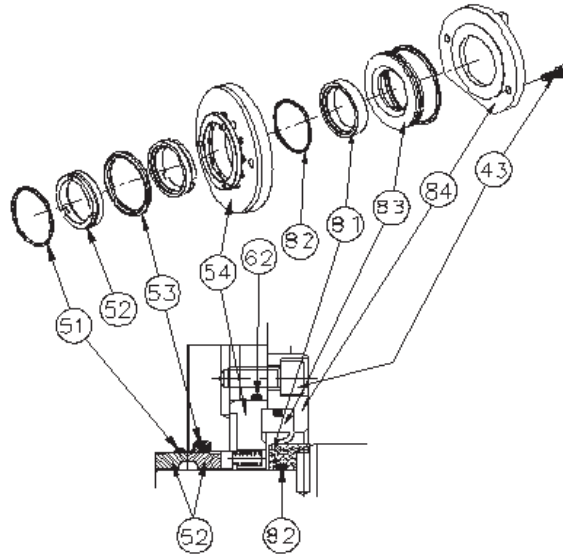

Item	Dixon Sanitary Part #	Description	Material	Used	Quantity		
					Per Assembly	Per Pump	
43	RZL-115B-MSGWB	Wrench Bolt, Lip Seal Gland (M6x10L)	SUS304	RZL100	2	4	
51	RZL-115B-RTORB	O-ring, Rotor (AN028)	NBR		1	2	
	RZL-115B-RTORE	O-ring, Rotor (AN028)	EPDM		1	2	
	RZL-115B-RTORV	O-ring, Rotor (AN028)	FKM		1	2	
	RZL-115B-RTORP	O-ring, Rotor (AN028)	Perfluoro		1	2	
	RZL-115B-TCSEAL	Mech. Seal Ring	TC		2	4	
52	RZL-115B-SCSEAL	Mech. Seal Ring	SiC		RZL120	2	4
	RZL-120-RHLTCSR	Seal Ring, Rubber Heli-lobe	TC			2	4
	RZL-120-RHLSCSR	Seal Ring, Rubber Heli-lobe	SiC			2	4
53	RZL-115B-RCORB	O-ring, Rotor Case (AN220)	NBR		RZL100	1	2
	RZL-115B-RCORE	O-ring, Rotor Case (AN220)	EPDM	1		2	
	RZL-115B-RCORV	O-ring, Rotor Case (AN220)	FKM	1		2	
	RZL-115B-RCORP	O-ring, Rotor Case (AN220)	Perfluoro	1		2	
54	RZL-115B-CSSB	Single Seal Body, Case	SUS304	1		2	
62	RZL-CORDSB	O-ring, Flushed Seal Case (AN036)	NBR	RZL100		1	2
	RZL-115B-CORDSE	O-ring, Flushed Seal Case (AN036)	EPDM			1	2
	RZL-115B-CORDSV	O-ring, Flushed Seal Case (AN036)	FKM			1	2
	RZL-115B-CORDSP	O-ring, Flushed Seal Case (AN036)	Perfluoro			1	2
81	RZL-115B-CERFL	Ceramic Sleeve, flushing	Ceramic			1	2
82	RZL-115B-ORFLB	O-ring, Ceramic Sleeve, Flushing (AN023)	NBR		RZL100	1	2
	RZL-115B-ORFLE	O-ring, Ceramic Sleeve, Flushing (AN023)	EPDM			1	2
	RZL-115B-ORFLV	O-ring, Ceramic Sleeve, Flushing (AN023)	FKM			1	2
	RZL-115B-ORFLP	O-ring, Ceramic Sleeve, Flushing (AN023)	Perfluoro			1	2
83	RZL-115B-LSFLT	Lip seal, flushing	PTFE		1	2	
84	RZL-115B-SLPFLG	Gland, Lip Seal, Flushing	SUS304	1	2		

Parts List for RZL-100 Series Pumps

Pressure Relief Front Cover

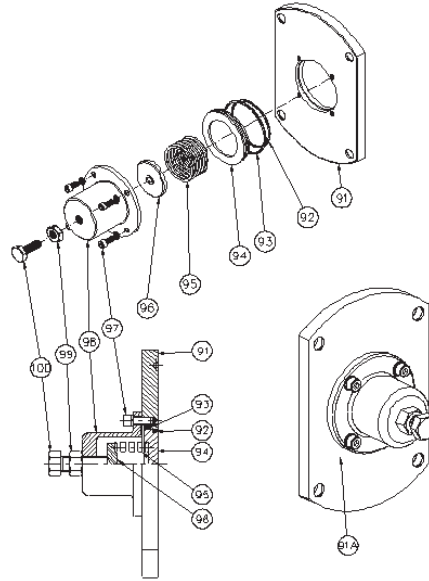

Item	Dixon Sanitary Part #	Description	Material	Used	Quantity	
					Per Assembly	Per Pump
91	RZL-105-RVFC	Front Cover, Relief Valve	SUS316L	RZL105	1	1
	RZL-110-RVFC	Front Cover, Relief Valve	SUS316L	RZL100	1	1
	RZL-115B-RVFC	Front Cover, Relief Valve	SUS316L	RZL115/120	1	1
91A	RZL-105-C	Pressure Relief Front Cover Ass'y	SUS316L	RZL105	1	1
	RZL-110-C	Pressure Relief Front Cover Ass'y	SUS316L	RZL110	1	1
	RZL-115B-C	Pressure Relief Front Cover Ass'y	SUS316L	RZL115/RZL120	1	1
92	RZL-115B-OR1B	O-ring, 1 stage, Plate (AN138)	NBR	RZL100	1	1
	RZL-115B-OR1E	O-ring, 1 stage, Plate (AN138)	EPDM		1	1
	RZL-115B-OR1V	O-ring, 1 stage, Plate (AN138)	FKM		1	1
	RZL-115B-OR1P	O-ring, 1 stage, Plate (AN138)	Perfluoro		1	1
93	RZL-115B-OR2B	O-ring, 2 stage, Plate (AN135)	NBR		1	1
	RZL-115B-OR2E	O-ring, 2 stage, Plate (AN135)	EPDM		1	1
	RZL-115B-OR2V	O-ring, 2 stage, Plate (AN135)	FKM		1	1
	RZL-115B-OR2P	O-ring, 2 stage, Plate (AN135)	Perfluoro		1	1
94	RZL-115B-VP	Plate, Valve	SUS316L		1	1
95	RZL-115B-RVSP	Spring	SS41 + Cr		1	1
96	RZL-115B-SPGP	Plate, Spring	SUS304		1	1
97	RZL-115B-RVWB	Wrench Bolt (M6x20) with washer	SUS304		4	4
98	RZL-115B-RVC	Cover, Relief Valve	SUS304		1	1
99	RZL-115B-RVLN	Lock Nut (M12)	SUS304		1	1
100	RZL-115B-RVAB	Adjusting Bolt (M12x60)	SUS304		1	1

Parts List for RZL-100 Series Pumps Jacket Front Cover and Case

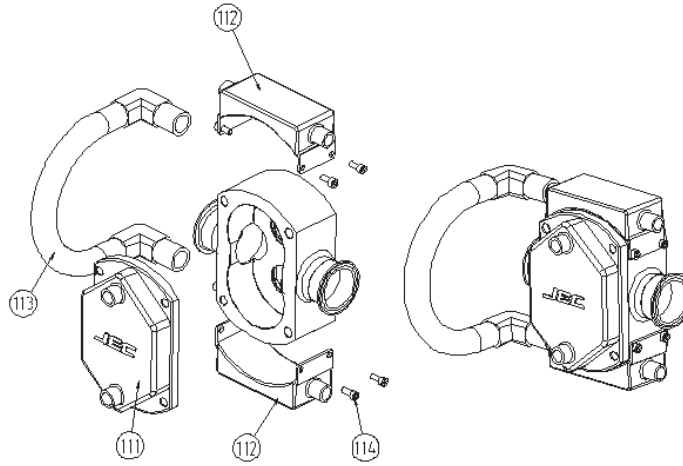

Item	Dixon Sanitary Part #	Description	Material	Used	Quantity	
					Per Assembly	Per Pump
111	RZL-105B-FCJ	Jacket, Front cover	SUS316L	RZL105/RZL110	1	1
	RZL-115B-FCJ	Jacket, Front cover	SUS316L	RZL115/RZL120	1	1
112	RZL-110B-CTJ	Jacket, Case top	SUS304	RZL110/115	1	1
	RZL-110B-CBJ	Jacket, Case bottom	SUS304		1	1
	RZL-120-CTJ	Jacket, Case top	SUS304	RZL120	1	1
	RZL-120-CBJ	Jacket, Case bottom	SUS304		1	1
113	RZL-115B-JT	Tube, Jacket	SUS304	RZL100	1	1
114	RZL-115B-JWB	Wrench Bolt, Jacket (M8x20)	SUS304	RZL100	1	2

Parts List for RZL-100 Series Pumps Rectangular Inlet

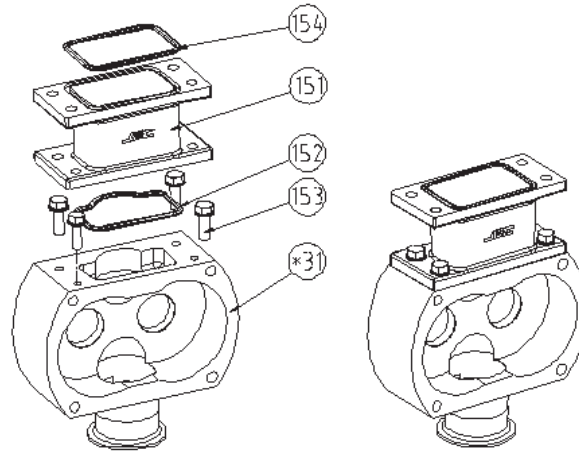

Item	Dixon Sanitary Part #	Description	Material	Used	Quantity	
					Per Assembly	Per Pump
151	RZL-120-RCRIA	Adaptor, Rectangular Inlet	SUS304	RZL120	1	1
152	RZL-120RIORB	O-ring, Rectangular Inlet (AN233)	NBR	RZL120	1	1
	RZL-120-RIOR	O-ring, Rectangular Inlet (AN233)	EPDM		1	1
	RZL-120-RIORV	O-ring, Rectangular Inlet (AN233)	FKM		1	1
	RZL-120-RIORT	O-ring, Rectangular Inlet (AN233)	PTFE		1	1
153	RZL-120-RIHBSW	Hex Bolt & S/W(M8x25)	SUS304	RZL120	1	4
154	RZL-120-ROORB	O-ring, Rectangular Outlet (AN234)	NBR	RZL120	1	1
	RZL-120-ROOR	O-ring, Rectangular Outlet (AN234)	EPDM		1	1
	RZL-120-ROORV	O-ring, Rectangular Outlet (AN234)	FKM		1	1
	RZL-120-ROORT	O-ring, Rectangular Outlet (AN234)	PTFE		1	1
31	RZL-120-RCD11	Rotor Case-RECT/2"DIN11851	SUS316L	RZL120	1	1
	RZL-120-RCD26	Rotor Case-RECT/2"DIN2633	SUS316L		1	1
	RZL-120-RDS	Rotor Case-RECT/2"DS722.1	SUS316L		1	1
	RZL-120-RISO	Rotor Case-RECT/2"ISOMALE	SUS316L		1	1
	RZL-120-RRJT	Rotor Case-RECT/2"RJT	SUS316L		1	1
	RZL-120-RSMS	Rotor Case-RECT/2"SMS	SUS316L		1	1
	RZL-120-RCRI2C	Rotor Case-RECT/2"TRICLAMP	SUS316L		1	1
	RZL-120-RFLG	Rotor Case-RECT/2"FLANGE	SUS316L		1	1

Certificates

ISSUE DATE: NOVEMBER 29, 2005

CERTIFICATE AUTHORIZATION NUMBER: 1397



THIS IS TO CERTIFY THAT

JEC Ltd.

32-8 Hwadang-Ri, Paltan-Myun Hwasung-Shi, Kyunggi-do 445-914 SOUTH KOREA

is hereby authorized to continue to apply the 3-A Symbol to the models of equipment, conforming to 3-A Sanitary Standards for:

Number 02-11
Centrifugal and Positive Rotary Pumps

set forth below

Rotary Lobes: JRZL105, JRZL110, JRZL115, JRZL120, JRZL220, JRZL225, JRZL330, JRZL340, JRZL440, & JRZL450; Centrifugal: JCP508, JCP510, JCP809, JCP812, JCP2210, JCP2214, JRZP015, JRZP030, JRZP060, JRZP130, & JRZP220; Centrifugal (WFI): JWP508, JWP510, JWP809, JWP812, JWP2210, & JWP2214.

VALID THROUGH: December 31, 2014

Timothy R. Rugh
Executive Director
3-A Sanitary Standards, Inc.

The issuance of this authorization for the use of the 3-A Symbol is based upon the voluntary certification, by the applicant for it, that the equipment listed above complies fully with the 3-A Sanitary Standards designated. Legal responsibility for compliance is solely that of the holder of this Certificate of Authorization, and 3-A Sanitary Standards, Inc. does not warrant that the holder of an authorization at all times complies with the provisions of the said 3-A Sanitary Standard. This in no way affects the responsibility of 3-A Sanitary Standards, Inc. to take appropriate action in such cases in which evidence of nonconformance had been established.

NEXT TPV INSPECTION/REPORT DUE: April 2017



1935/2004 (EC) Declaration of conformity

Producer: JEC Ltd. (15-26, Beodeul-ro 1362, Hwasong-Si, Gyeonggi-Do, South Korea)
Product: JEC Rotary lobe pump
Model: RZL series

We, JEC, hereby guarantee that the materials are in direct contact with food as below,

SS316L, SIC seal ring, PTFE Glass filler and EPDM O-ring

Complies with the following relevant regulations:

- 1935/2004 (EC)
- Annex IV of Regulation (EC) 10/2011
- BFR Recommendation XXI

This declaration of conformity has been established on the basis of the following:

No.	Parts	Test requested	Test done
1	Wetted parts (SS316L)	German Food, Articles of Daily use and Feed Code of September 1, 2005(LFGB) Section 30 German Food, Articles of Daily use and Feed Code of September 1, 2005(LFGB) Section 31	Extractable Heavy metals Sensory examination odor and taste
2	Seal ring (SIC)	German Food, Articles of Daily use and Feed Code of September 1, 2005(LFGB) Section 30	Extractable Heavy metals
3	Lip seal (PTFE With Glass Filler)	German Food, Articles of Daily use and Feed Code of September 1, 2005(LFGB) Section 31 Commission Regulation(No. 10/2011) and Hence Article 3 of European Regulation No. 1935/2004	1. Overall Migration 2. Specific Migration of Heavy metal Sensory examination odor and taste
4	O-ring (EPDM)	BFR Recommendation XXI European Commission Directive 93/11/EEC	1. Overall Migration 2. Specific migration of Primary Aminals amine 3. Lead and Zinc content 4. Specific migration of Formaldehyde 5. Organotin content Specific migration of nitrosamines

James Song / President

JEC LTD. 15-26, Beodeul-ro, Paltan-myun, Hwasong-si, Gyeonggi-do, 445-914, South Korea
Tel : 82-31-355-0316, Fax : 82-31-355-0319

Certificates



EC-Declaration of conformity (as per EC's Machinery Directive 2006/42/EC, Annex IIA)

Producer
JEC LTD
15-26, Beodeul-ro 1362, Hwasung-Si,
Kyunggi-do, South Korea

We hereby guarantee that **Lotary lobe pump (Pump Head Only)**
Type: **JRZL series**

are in conformity with the essential requirements of the EC's Machinery Directive 2006/42/CE (latest modifications included) and according to the following Council Directives and harmonized norms:
- 2006/95/EC Directive "low voltage"
- UNI EN ISO 12100-2:2005

Manufacturer Declaration (as per EC's Machinery Directive 2006/42/CE, Annex IIB)

We hereby declare that the above pumps,
Comply with the pertinent disposition, in the execution supplied by JEC LTD for the incorporation in a machine or installation, or for the assembly with other machines as a subunit of other higher order machine. Harmonized norms used, particularly:

UNI EN ISO 12100-2:2005

The machine above must not be put into service until the machinery into which it has been incorporated have been declared in conformity with the EC Machinery Directive. It must meet, particularly, the standards ISO 23857:2008, ISO 13732-1:2007 in its respective current editions.

James Song / President

JEC LTD, 15-26, Beodeul-ro, Paltan-myun, Hwasung-si, Gyeonggi-do, 445-843, South Korea
Tel : 82-31-355-0316, Fax : 82-31-355-0319

ATEX Certificate



Konformitätserklärung EC declaration of conformity

as defined by EC machinery directive 98 / 37 / EG, Anhang IIA
as defined by EC machinery directive 98 / 37 / EC, Annex I A

Produkt: Product	Kreislobspumpe Rotary Lobe Pump
Modell: Serial No.	JRZL series JECF-0000
Max. Arbeitsdruck: max. working pressure:	bis 12 bar to 12 bar
Drehzahl: Speed	<600 min ⁻¹ (+/-10%)
Kennzeichnung: Marking	II 2G c T4

Hiermit erklären wir, dass die Pumpentypen, mit den folgenden Richtlinien übereinstimmen.
We declare that the pump types, complies with the following relevant regulations:

EG - Maschinenrichtlinie 98 / 37 / EG, Anhang I Nr. 1
EC machinery directive 98 / 37 / EG, Annex I No. 1

EG - Richtlinie 94 / 9 / EC für Geräte in explosionsgefährdeten Bereichen
EC directive 94 / 9 / EC for equipment for the use in potentially explosive atmospheres

Entsprechend Artikel 8(1)(b)(i) der Richtlinie 94/9/EG ist die technische Dokumentation bei der benannten Stelle hinterlegt.
IBEXU, Institut für Sicherheitstechnik, Fuchsmühlweg 7, 09599 Freiberg

According to article 8(1)(b)(i) of guide line 94 / 9 / EC the technical documentation is deposited at the nominated location.
IBEXU, Institute for Safety Technology, Fuchsmuehlenweg 7, 09599 Freiberg, Germany

Angewandte harmonisierte Normen:
Applicable harmonized standards:

EN 292-1, EN 292-2, EN 809, EN 294, EN 663, EN 963
EN1127-1, EN 13463-1, EN 13463-6

Die Sicherheitshinweise der Betriebsanleitung sind zu beachten!
The safety instructions of the operating manual must be followed!

July 28 2009
Date

James Song / President

JEC LTD, 33-B, Heodang ri, Paltan-myun, Hwasung-si, Gyeonggi-do, 440-843, South Korea
Tel : 82-31-355-0316, Fax : 82-31-355-0319

Limited Warranty

Dixon Sanitary, a division of Dixon Valve and Coupling Company, (herein called Dixon Sanitary) warrants the products described herein, and manufactured by Dixon Sanitary to be free from defects in material and workmanship for a period of one (1) year from date of shipment by Dixon Sanitary under normal use and service. It's sole obligation under this warranty being limited to repairing or replacing, as hereinafter provided, at its option any product found to Dixon Sanitary's satisfaction to be defective upon examination by it, provided that such product shall be returned for inspection to Dixon Sanitary within three (3) months after discovery of the defect. The repair or replacement of defective products will be made without charge for parts or labor. This warranty shall not apply to: (a) parts or products not manufactured exclusively for Dixon Sanitary, the warranty of such items being limited to the actual warranty extended to Dixon Sanitary by its supplier; (b) any product that has been subject to abuse, negligence, accident, or misapplication; (c) any product altered or repaired by others than Dixon Sanitary; and (d) to normal maintenance services and the replacement of service items (such as gaskets and seats) made in connection with such services. To the extent permitted by State law, this limited warranty shall extend only to the buyer and any other person reasonably expected to use or consume the goods who is injured in person by any breach of the warranty. No action may be brought against Dixon Sanitary for an alleged breach of warranty unless such action is instituted within one (1) year from the date the cause of action accrues. This limited warranty shall be construed and enforced to the fullest extent allowable by applicable State law.

OTHER THAN THE OBLIGATION OF DIXON SANITARY SET FORTH HEREIN, DIXON SANITARY DISCLAIMS ALL WARRANTIES, EXPRESS OR IMPLIED, INCLUDING BUT NOT LIMITED TO ANY IMPLIED WARRANTIES OF MERCHANTABILITY OR FITNESS FOR A PARTICULAR PURPOSE, AND ANY OTHER OBLIGATION OR LIABILITY. THE FOREGOING CONSTITUTES DIXON SANITARY SOLE OBLIGATION WITH RESPECT TO DAMAGES, WHETHER DIRECT, INCIDENTAL OR CONSEQUENTIAL, RESULTING FROM THE USE OR PERFORMANCE OF THE PRODUCT.

Some products and sizes may be discontinued when stock is depleted, or may require a minimum quantity for ordering.

NOTE: Reasonable care has been taken in preparing this catalog. Dixon Sanitary, a division of Dixon Valve & Coupling Company, reserves the right to make corrections and any dimensional changes.

Dixon, founded in 1916, is a premier manufacturer and supplier of hose couplings, valves, dry-disconnects, swivels, and other fluid transfer and control products. The company's global reach includes a wide range of products for numerous industries including petroleum exploration, refining, transportation, chemical processing, food & beverage, steel, fire protection, construction, mining and manufacturing. Dixon's strategic objective is to create solutions that make products safer, leak-free, longer lasting, and always available.

dixonvalve.com • *Customer Service:* **800.789.1718**



The Right Connection®

Dixon Sanitary

N25 W23040 Paul Road • Pewaukee, WI 53072

Customer Service: 800.789.1718

Fax: 800.789.4046



YouTube™



Dixon
Customer Service